

Model 5192

Parallel Opposed Dual Pyroelectric IR Detector with JFET Amplifier



Manufactured under one or more of the following U.S. patents: 3,839,640 - 4,218,620 - 4,326,663 - 4,384,207 - 4,437,003 - 4,441,023 - 4,523,095

Model 5192 consists of two physically separated lithium tantalate sensing elements and a JFET amplifier sealed into a standard TO-5 housing with an optical filter.

The sensing elements are connected electrically in a parallel opposed dual (POD) configuration for common mode signal cancellation. Signals from radiation falling on both active areas simultaneously will be cancelled, whereas a defined beam passing from one element to the next will produce two pulses: one positive and one negative.

A source resistor, R_S , is needed to set the drain current and consequently the operating parameters of the JFET. A 47k Ω or greater value resistor is recommended.

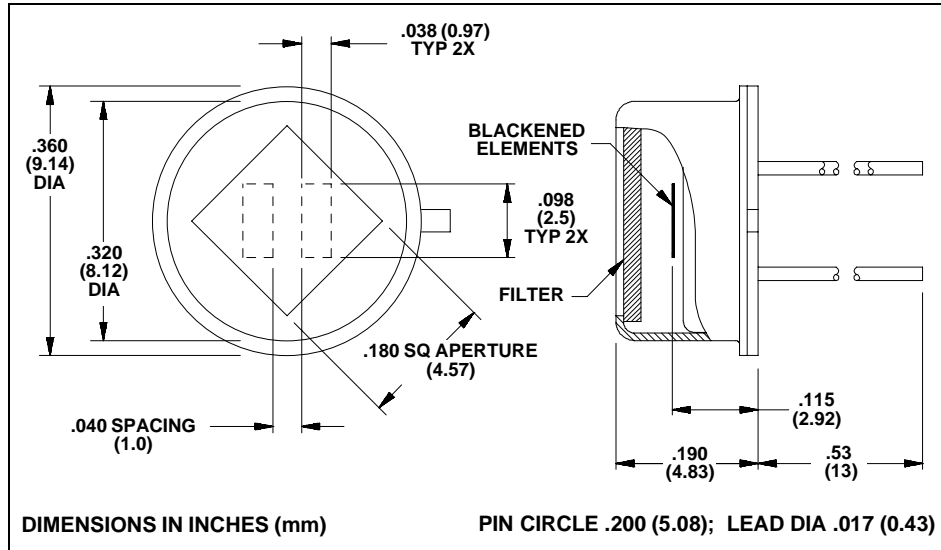

Applications

- Intrusion Detection
- Lighting Control
- Robotics
- Motion Sensing
- Automatic Door Control
- Safety Warning
- People Detector

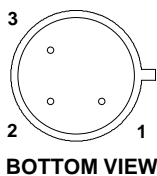
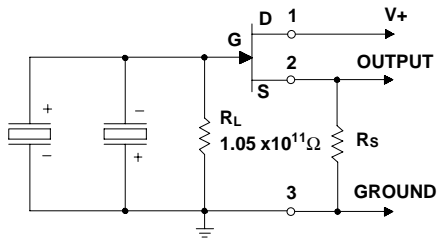

- PIN DESIGNATIONS**
1. V+
 2. OUTPUT
 3. GND/CASE

Characteristics	5192	Unit	Test Conditions	ELTECdata Reference
Detector Type	POD			
Element Size	1.0 x 2.5	mm, each		
Element Spacing	1.0	mm	Nominal	
Optical Bandwidth	0.1 to 1,000	μm	Various Filters	101
Responsivity (min) (Each Element)	2,760	V/W	8 to 14 μm , 1 Hz	
	(typ) 3,850			
Common Mode Rejection Ratio (min)	5:1		8 to 14 μm , 1 Hz	
	(typ) 15:1			
Noise (typ)	1.7	$\mu\text{Vrms}/\sqrt{\text{Hz}}$	1 Hz, 1 Hz BW	
	(max) 8.51			
NEP (typ)	4.5×10^{-10}	$\text{W}/\sqrt{\text{Hz}}$	8 to 14 μm , 1 Hz, 1 Hz BW	100
	(max) 3.1×10^{-9}			
D^* (min)	0.5×10^8	$\text{cm}/\sqrt{\text{Hz}/\text{W}}$	8 to 14 μm , 1 Hz, 1 Hz BW	100
	(typ) 3.4×10^8			
Operating Voltage (min)	3	VDC	V+ to Gnd	104
	(max) 15			(4.1.c)
Operating Current (min)	3	μA	$R_S = 100\text{k}\Omega$	104
	(max) 12			(4.1.c)
Offset Voltage (min)	0.3	V	$R_S = 100\text{k}\Omega$	106
	(max) 1.2			Section B
Output Impedance	$< R_S$	Ω		
Thermal Breakpoint f_T (typ)	0.2	Hz		102
Electrical Breakpoint f_e (typ)	0.05	Hz	$R_L = 1.05 \times 10^{11}\Omega$	102
Recommended Operating Temperature	-10 to +50	$^\circ\text{C}$	Functional	
Storage Temperature	-55 to +125	$^\circ\text{C}$	$\Delta T < 50\text{ }^\circ\text{C}/\text{min}$	
Output Protection	Do not exceed a maximum drain current of 50 μA			

Characteristics 25 $^\circ\text{C}$, with -3 filter, $R_S = 100\text{k}\Omega$, $V_+ = 5\text{ VDC}$ unless otherwise stated. Data is established on a sample basis and is believed to be representative.

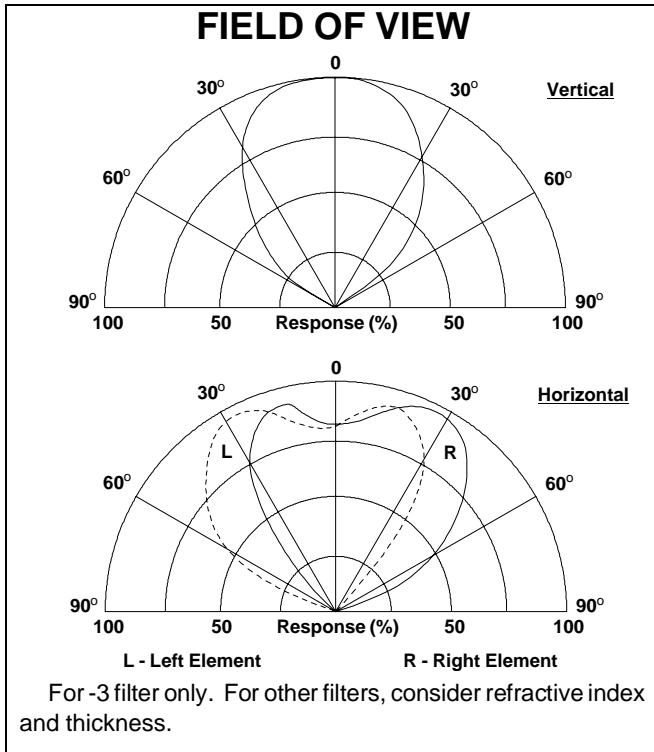

For best results, the following precautions and recommendations should be observed. (See ELTECdata # 101):

Mounting: Avoid mechanical stresses on case and leads.

Soldering: Detectors must be hand soldered to minimize the chance of destroying the internal components. Avoid machine or hot air soldering. Leave a minimum lead length of .250 inch (6.35mm). When soldering to detector leads, use a heat sink between the case and leads. Beware that the new RoHS compliant solders require a higher soldering temperature making heat sinking the detector extremely important.

Static Discharge: Protect detectors from electro-static charges.

Transmission Characteristics of -3 Filter (HP7)

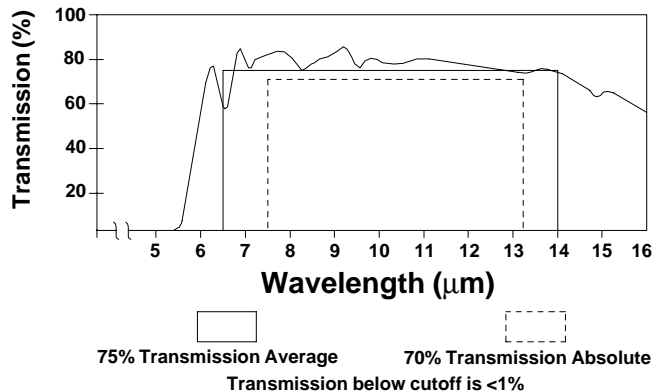

For information on other standard windows available, refer to ELTECdata # 101

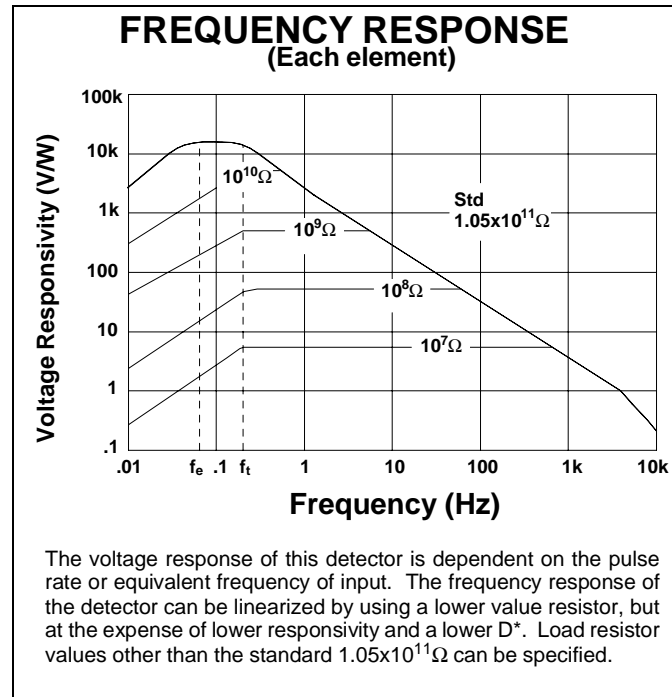

Thermal Shock: Temperature changes and rate of change must be kept to a minimum ($<50^\circ\text{C}/\text{min.}$) to prevent damage.

Noise: As a resolution or lower information limit, noise is established not only by the detector. Other noise sources are:

- Radiated and conducted RF signals
- Subsequent amplification or signal conditioning stages
- Power supply noise
- Components, such as high value resistors and capacitors (tantalum and aluminum electrolytic)
- Mechanical contacts and weak solder joints
- Shock and vibration excited microphonics
- Outside thermal influences on the detector other than the desired infrared input, i.e. drafts

All of these noise sources should be considered carefully when the information signal is $<1\text{mV}$.

Light Leakage: Slight sensitivity to visible light leaking through the glass-to-metal seal on the base may be observed.

Optical Design: Use of a detector with a filter in an optical system may require consideration of the image displacement toward the filter. This displacement (s) caused by the insertion of a planoparallel plate (filter thickness = t; refractive index = N) is given by $s = (t/N)(N-1)$.

NOTICE: The information provided herein is believed to be reliable. However, ELTEC Instruments, Inc. assumes no responsibility for inaccuracies or omissions. Due to industry components being incorporated into ELTEC's devices and ELTEC continually striving for product improvement, specifications may change without notice.