

# Model 40612

## Pyroelectric IR Detector with Internal JFET and Load/Feedback Resistor



Manufactured under one or more of the following U.S. patents: 3,839,640 - 4,218,620 - 4,326,663 - 4,384,207 - 4,437,003 - 4,441,023 - 4,523,095

**Model 40612** consists of a single lithium tantalate sensing element, JFET and high value resistor sealed into a 4-pin TO-5 transistor housing with an optical filter.

When compared to the Model 406, Model 40612 has a reduced low frequency response, allowing for excellent stability. It also features optimum signal-to-noise performance in the 1 - 10 Hz frequency range.

The electronics are configured so the detector can be operated in two ways: (1) As a voltage mode detector with an integral JFET source follower or (2) as a current mode detector with the JFET to be used as the input to an external operational amplifier and the high value resistor used for the feedback resistance.

An external source resistor is needed to set the drain current and consequently the operating parameters of the JFET. A 47k $\Omega$  to 1.0M $\Omega$  resistor is recommended.

### Applications

- Flame Detection
- Industrial Control
- Motion Sensing
- Gas Analysis
- Pyrometry
- Instrumentation
- Furnace Flame Control

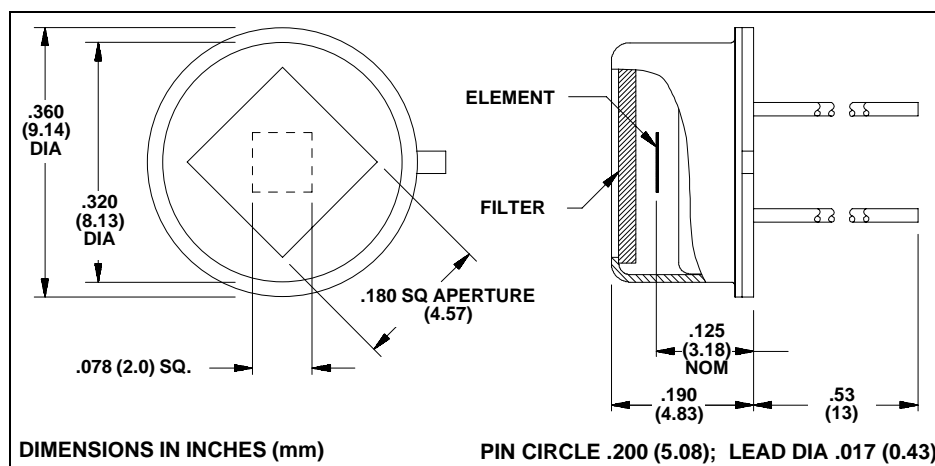

Characteristics	40612	Unit	Test Conditions	ELTECdata Reference
Detector Type	Single			
Element Size	2.0 x 2.0	mm		
Optical Bandwidth	0.1 to 1,000	$\mu\text{m}$	Various Filters	101
Responsivity (typ)	220	V/W	4.17 to 4.79 $\mu\text{m}$ @10Hz	
Noise (typ)	1.88	$\mu\text{Vrms}/\sqrt{\text{Hz}}$	10 Hz	
NEP (typ)	$8.5 \times 10^{-9}$	$\text{W}/\sqrt{\text{Hz}}$	4.17 to 4.79 $\mu\text{m}$ , 10 Hz, 1 Hz BW	100
D* (typ)	$2.3 \times 10^7$	$\text{cm}\sqrt{\text{Hz}}/\text{W}$	4.17 to 4.79 $\mu\text{m}$ , 10 Hz, 1 Hz BW	100
Operating Voltage (min)	3	VDC	V+ to Gnd	104
Operating Voltage (max)	15	VDC	V+ to Gnd	(4.1.c)
Operating Current (min)	0.1	$\mu\text{A}$	$R_S = 100\text{k}\Omega$	104
Operating Current (max)	40	$\mu\text{A}$	$R_S = 100\text{k}\Omega$	(4.1.c)
Offset Voltage (min)	0.3	V	$R_S = 100\text{k}\Omega$	104
Offset Voltage (max)	1.2	V	$R_S = 100\text{k}\Omega$	Fig. 4
Output Impedance	$\leq R_S$	$\Omega$		
Thermal Breakpoint $f_T$ (typ)	0.24	Hz		102
Electrical Breakpoint $f_e$ (typ)	1.2	Hz	$R_L = 4 \times 10^9 \Omega$	102, 134
Recommended Operating Temperature	-10 to +50	$^{\circ}\text{C}$	Functional	
Storage Temperature	-55 to +125	$^{\circ}\text{C}$	$\Delta T < 50\text{C}^{\circ}/\text{min}$	
Output Protection	Do not exceed a maximum drain current of 50 $\mu\text{A}$			

Characteristics are in the Voltage Mode at 25 $^{\circ}\text{C}$ , with -23 filter, V+ = 8 VDC,  $R_S = 100\text{k}\Omega$  unless otherwise stated.

Data established on a sample basis and is believed to be representative.

## Recommended Operation of Model 40612

Power Supply:  $\pm 6$  Volts to  $\pm 15$  Volts

### Current Mode Operation

- High Gain
- Flat Response from .5 to 100 Hz

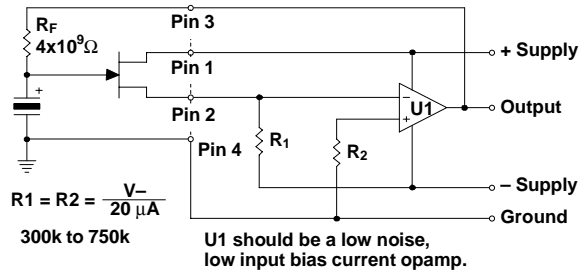

### Voltage Mode Operation

- Simple
- Lowest possible noise
- Maximum response at 1 Hz

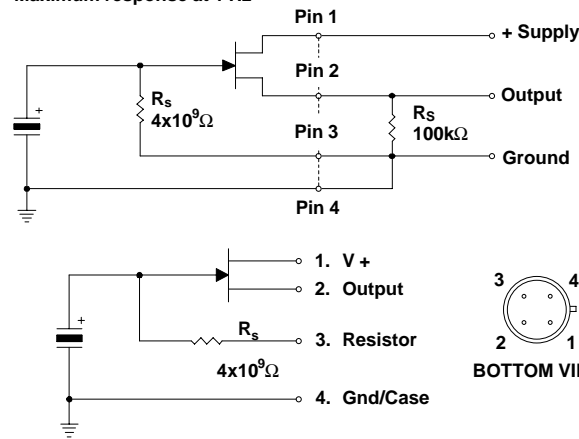

**Field of View:** Approximately  $110^\circ$  (50% power points)

**Mounting:** Avoid mechanical stresses on case and leads.

**Soldering:** Detectors must be hand soldered to minimize the chance of destroying the internal components. Avoid machine or hot air soldering. Leave a minimum lead length of .250 inch (6.35mm). When soldering to detector leads, use a heat sink between the case and leads. Beware that the new RoHS compliant solders require a higher soldering temperature making heat sinking the detector extremely important.

**Static Discharge:** Protect detectors from electro-static charges.

**Thermal Shock:** Temperature changes and rate of change must be kept to a minimum ( $<50^\circ\text{C}/\text{min.}$ ) to prevent damage. See Gate Protection note.

## FREQUENCY RESPONSE

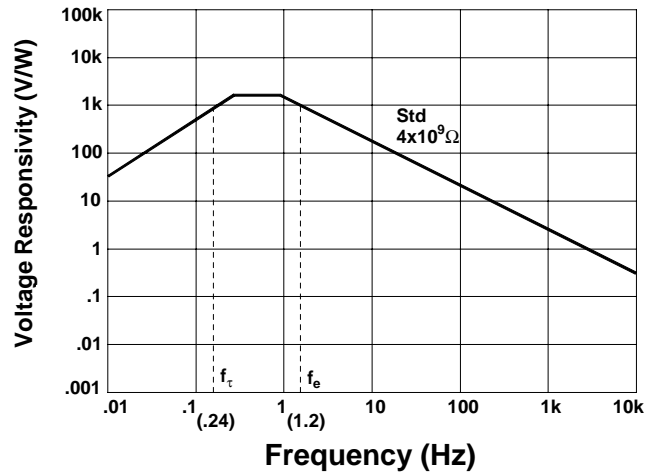

The voltage response of this detector is dependent on the pulse rate or equivalent frequency of input.

**Noise:** As a resolution or lower information limit, noise is established not only by the detector. Other noise sources are:

- Radiated and conducted RF signals
- Subsequent amplification or signal conditioning stages
- Power supply noise
- Components, such as high value resistors and capacitors (tantalum and aluminum electrolytic)
- Mechanical contacts and weak solder joints
- Shock and vibration excited microphonics
- Outside thermal influences on the detector other than the desired infrared input, i.e. drafts

All of these noise sources should be considered carefully when the information signal is  $<1\text{mV}$  for voltage mode operation and  $20\text{mV}$  for current mode operation.

**Gate Protection:** Treat as static sensitive devices because voltages to 100 volts can be generated in the crystal by rapid temperature changes. If the internal resistor is not connected to some path to ground, the full voltage will be presented to the JFET gate with possible JFET failure. The electroded sensing crystal (a dielectric sandwich) can be regarded as a self-generating capacitor with an RC discharge time constant of greater than 5 minutes.

**Light Leakage:** Slight sensitivity to visible light leaking through the glass-to-metal seal on the base may be observed.

**Optical Design:** Use of a detector with a filter in an optical system may require consideration of the image displacement toward the filter. This displacement (s) caused by the insertion of a planoparallel plate (filter thickness = t; refractive index = N) is given by  $s = (t/N)(N-1)$ .

**NOTICE:** The information provided herein is believed to be reliable. However, ELTEC Instruments, Inc. assumes no responsibility for inaccuracies or omissions. Due to industry components being incorporated into ELTEC's devices and ELTEC continually striving for product improvement, specifications may change without notice.