

## QL78H6SA/B/C/D

- 780nm 20mW 60°C

- Infrared Laser

Feb. 2019 (Ver. 4)

### • Application

- Industrial Optical Sensor
- Laser Printer

### • Features

- 780nm Infrared Laser
- CW laser (Continuous Wave)
- Single Transversers / TE mode laser
- 5.6mm Package

### • Electrical Connection

P/N	Pin Configuration	Internal Circuit
QL78H6SA/B/C/D	<p><b>Bottom View</b></p>	<p>A type</p> <p>B type</p> <p>C type</p> <p>D type</p>

## 1. ABSOLUTE MAXIMUM RATING

Item	Symbols	Values	Unit
Optical Output Power	P	20	mW
Laser Diode Reverse Voltage	V	2	V
Photo Diode Reverse Voltage	V	30	V
Operating Temperature	T <sub>opr</sub>	-10 ~ +60	°C
Storage Temperature	T <sub>stg</sub>	-40 ~ +85	°C

## 2. ELECTRICAL and OPTICAL CHARACTERISTICS at Tc=25°C

Item	Symbol	Min	Typ	Max	Unit	Condition
Threshold Current	I <sub>th</sub>	-	15	20	mA	-
Operating Current	I <sub>op</sub>	20	35	50	mA	P <sub>o</sub> =20mW
Operating Voltage	V <sub>op</sub>	1.6	1.9	2.3	V	P <sub>o</sub> =20mW
Slope Efficiency	η <sub>s</sub>	0.5	0.9	1.4	mW/mA	(20mW-10mW)/(I(20mW)-I(10mW))
Lasing Wavelength	λ <sub>p</sub>	775	788	800	nm	P <sub>o</sub> =20mW
Beam Divergence	θ <sub>∥</sub>	8.5	11	14	deg	P <sub>o</sub> =20mW FWHM
	θ <sub>⊥</sub>	26	30	34	deg	
Beam Angle	Δθ <sub>∥</sub>	-2	-	+2	deg	P <sub>o</sub> =20mW
	Δθ <sub>⊥</sub>	-3	-	+3	deg	P <sub>o</sub> =20mW
Monitor Current	I <sub>m</sub>	0.8	-	2.2	mA	P <sub>o</sub> =20mW
Optical Distance	ΔX, ΔY, ΔZ	-60	-	+60	um	-

Note : Tc = Case (Stem) temperature

- Use in APC condition with heat sink and do not exceed 20mW 60°C

- The products and product specifications are subject to change without notice.

## 3. PACKAGE DIMENSION (unit : mm)

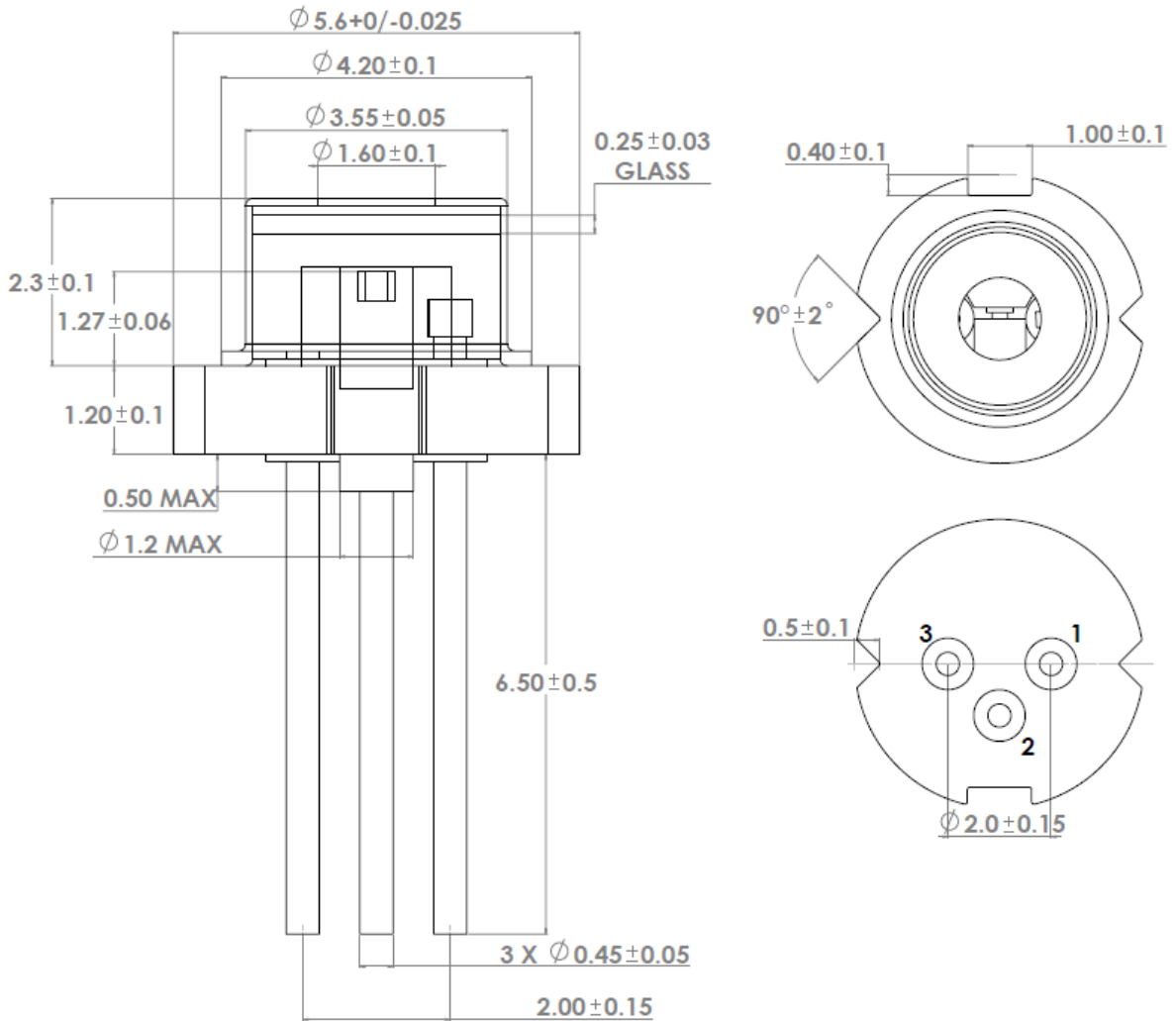

Note : Tolerance is  $\pm 0.05\text{mm}$  for items without tolerance marking

## 4. PACKING

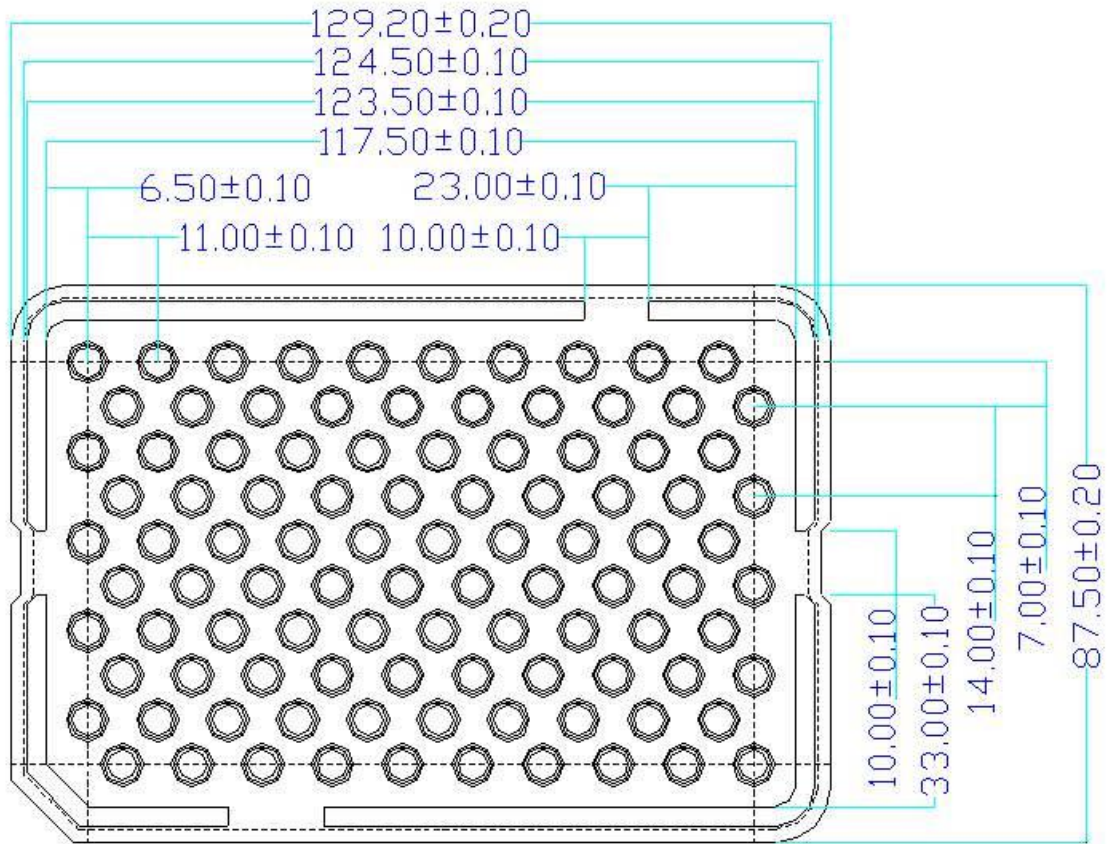

## 5. PRECAUTIONS

### 1) Absolute maximum ratings

The absolute maximum ratings which must not be exceeded even momentarily have been established for over driving laser operation reason such as COD. Exercise particular caution with respect to the drive voltage supply and static electricity.

### 2) Prevention of surge current and electrostatic discharge(ESD) and surge stress

Laser diode is sensitive device to ESD and surge, so even an extremely short time, laser diode damaged with the strong light emitted.

Use the power supply that was designed not to exceed the optical power output specified at the absolute maximum ratings

We advise taking the following protective measures

- Ground the device and circuits
- When working with laser diodes wear anti-static clothing.  
Grounded wrist straps should always be worn while working with laser diodes.
- Use anti-static containers for transport and storage.
- Laser diode deterioration and damage can occur due to excessive current spikes when the power is turned on or off.  
Design circuits to avoid the generating of excessive current spikes

### 3) Soldering

When soldering, please give attention to the mechanical stress and the temperature. Temperature of die-pad portion should be less than 200°C.

It is recommended to radiate heat by putting heat sink on the package.

※ Soldering temperature and time : Iron temperature less than 350°C within 3sec (leads only)

### 4) Eye Safety

When the laser diode is in operation, looking into laser beam directly by naked eyes, even through a lens, microscope or optical fibers, may cause severe damage to human eyes. For observing laser beams, using safety goggles is recommended