



## Balanced Amplified Photodetectors

# PDB4x5 Series Operation Manual



2023

---

Version: 1.3  
Date: 06-Feb-2023

Item No.: M0009-510-1044

# Contents

<b>Foreword</b>	<b>2</b>
<b>1 General Information</b>	<b>3</b>
1.1 Safety	3
1.2 Ordering Codes and Accessories	3
<b>2 Installation</b>	<b>4</b>
2.1 Parts List	4
2.2 Getting Started	4
<b>3 Operating Instruction</b>	<b>5</b>
3.1 Operating Principle	5
3.2 Optical Inputs	6
3.3 Electrical Outputs	8
3.4 Mounting	9
3.5 AC Coupling of the Outputs	9
3.6 CMRR and Frequency Response	10
3.7 Recommendations	11
<b>4 Maintenance and Service</b>	<b>12</b>
<b>5 Appendix</b>	<b>13</b>
5.1 Technical Data	14
5.1.1 PDB415x Individual Technical Data	16
5.1.2 PDB425x Individual Technical Data	19
5.1.3 PDB435x Individual Technical Data	22
5.1.4 PDB465x Individual Technical Data	25
5.2 Dimensions	28
5.3 Certifications and Compliances	29
5.4 Warranty	30
5.5 Copyright and Exclusion of Liability	30
5.6 Thorlabs Worldwide Contacts	31

---

We aim to develop and produce the best solution for your application in the field of optical measurement technique. To help us to live up to your expectations and constantly improve our products we need your ideas and suggestions. Therefore, please let us know about possible criticism or ideas. We and our international partners are looking forward to hearing from you.

*Thorlabs GmbH*

## **Warning**

Sections marked by this symbol explain dangers that might result in personal injury or death. Always read the associated information carefully, before performing the indicated procedure.

## **Attention**

Paragraphs preceded by this symbol explain hazards that could damage the instrument and the connected equipment or may cause loss of data.

## **Note**

This manual also contains "NOTES" and "HINTS" written in this form.

Please read this advice carefully!

# 1 General Information

The Thorlabs PDB4x5 Series Balanced Amplified Photodetectors succeed the PDB4x0 series with significant improved harmonic distortions by a complete redesign of the output stage.

They consist of two well-matched photodiodes and an ultra-low noise, high-speed transimpedance amplifier that generates an output voltage (RF OUTPUT) proportional to the difference between the photo currents in the two photodiodes, i.e. the two optical input signals. Additionally, the unit has two fast monitor outputs (MONITOR+ and MONITOR-) to measure the individual optical input power level as well as low frequency modulated signals on each detector separately.

For the PDB4x5 Series housing, an adapter can be attached to the bottom or side surface for post mounting. This adapter supports #8-32 as well as M4 post mounts.

The PDB4x5 Series is supplied with an external linear power supply.

The [Getting Started](#) section gives an overview of how to set up the PDB4x5 Series Balanced Amplified Photodetectors. Subsequent sections contain detailed information about principle of operation, operating suggestions, and technical specifications.

## 1.1 Safety

### **Attention**

**The safety of any system incorporating the equipment is the responsibility of the assembler of the system.**

**All statements regarding safety of operation and technical data in this instruction manual will only apply when the unit is operated correctly as it was designed for. The PDB4x5 Series must not be operated in explosion endangered environments!**

**Do not remove covers! Do not open the cabinet. There are no parts serviceable by the operator inside!**

**This precision device is only serviceable if properly packed into the complete original packaging including the plastic foam sleeves. If necessary, ask for replacement packaging.**

**Refer servicing to qualified personnel!**

**Only with written consent from Thorlabs may changes to single components be made or components not supplied by Thorlabs be used.**

## 1.2 Ordering Codes and Accessories

The following models of the PDB4x5 Series are available:

<b>PDB415</b>	100 MHz, fixed gain Balanced Amplified Photodetectors
<b>PDB425</b>	75 MHz, OCT-proved fixed gain Balanced Amplified Photodetectors
<b>PDB435</b>	350 MHz, fixed gain Balanced Amplified Photodetectors
<b>PDB465</b>	200 MHz, fixed gain Balanced Amplified Photodetectors

According to Thorlabs general detector part numbering system, the suffix "A" indicates Si photodiodes while the suffix "C" indicates InGaAs photodiodes.

Thorlabs offers AC-coupled versions. Special versions (open detector - cover glass removed) are available - except for PDB435C and PDB465C - on request - please contact [Thorlabs](#) for details.

## 2 Installation

This section is intended to provide information that explains how to quickly set up the PDB4x5 Series Balanced Amplified Photodetectors. More details and advanced features are described in further sections.

### 2.1 Parts List

Inspect the shipping container for damage.

If the shipping container seems to be damaged, keep it until you have inspected the contents and you have inspected the item mechanically and electrically.

Verify that you have received the following items within the package:

1. PDB4x5 Balanced Amplified Photodetector
2. Adapter Plate with four M2x8 screws and a hex key 1.5, for post-mounting the unit on a optical table
3. [LDS12B](#) power supply ( $\pm 12$  V, 250 mA), switchable to 100 V, 120 V, or 230 V line voltage
4. Operation manual

### 2.2 Getting Started

#### Note

Prior to operation, please check if the indicated line voltage range on the power supply matches with your local mains voltage! If you want use your own power supply, Thorlabs offers an appropriate power connector cable.

- Carefully unpack the unit and accessories. If any damage is noticed, do not use the unit. Contact [Thorlabs](#) and have us replace the defective unit.
- If required, mount the unit on your optical table or application. Therefore, mount the adapter plate on bottom or side wall using the four M2x8 screws first. The adapter plate has two mounting holes, M4 and #8-32. The M4 thread is marked. These threads can be used for mounting onto Thorlabs posts.
- If required, mount external optics, filters, apertures or fiber adapters.
- Set the power supply to your local mains voltage (100, 120, or 230 VAC):



Voltage Selector Switch

- Connect the DC output cable of the power supply to the POWER IN jack.
- Connect the power supply to the AC outlet and turn power supply on.
- Connect RF OUTPUT with coaxial cable to the data acquisition device.
- If necessary, connect monitor outputs (MONITOR+, MONITOR-) to measure the optical input power for each channel individually.

## 3 Operating Instruction

- Turn the power switch of the power supply to **I**. The green LED next to the DC input connector indicates that the power supply is operating correctly.
- Connect the optical source(s) to the optical input(s). The FC adapter will accommodate multi-mode as well as single-mode fiber.

### Attention

Be very careful about the force when connecting the fibers to the optical inputs! The photodiodes are mounted in such way, that the gap between the protective diode glass and the fiber tip is as small as possible. For this reason, **do not tighten** the fiber connector extremely in order to avoid damage to the glass window that protects the photodiode.

- For free-space beam applications, the FC adapters can be removed in order to have direct access to the photodetectors (not for PDB435C and PDB465C - see section ["Optical Inputs"](#) for details).
- The MONITOR outputs can be used to conveniently check the detected signal from each free space input beam. The maximum output voltage swing of the MONITOR outputs is 10V for high impedance loads (1.5 V into 50  $\Omega$  loads). Saturation of the MONITOR outputs will occur at optical input power greater than 1 mW.
- The RF output signal must not exceed the maximum RF OUTPUT voltage swing (see [Technical Data](#)) to avoid saturation.
- For balanced operation illuminate both photodetectors simultaneously and use either the RF OUTPUT or the MONITOR outputs to fine-tune the optical power balance by observing voltage on a digital voltmeter or other low-frequency measurement device.
- Do not exceed a maximum power density of 4 W/cm<sup>2</sup> for maximum linearity performance when measuring focused beams, fiber outputs, or small diameter beams.
- After finishing measurements, turn power off.

### Note

To prevent saturation of the balanced amplifier make sure that the power difference between the optical inputs remains less than the saturation power level (see "RF OUT CW Saturation Power" in the [Technical Data section](#)).

### Attention

The damage threshold of the photo diodes is 20 mW! Exceeding this value will permanently destroy the detector!

## 3.1 Operating Principle

Thorlabs PDB4x5 Series Balanced Amplified Photodetectors consist of two well-matched photodiodes and an ultra-low noise, high-speed transimpedance amplifier with low harmonic distortions. The output voltage (**RF OUTPUT**) is proportional to the difference between the photo currents of the two photodiodes, i.e. the difference of between the two optical input signals.

Additionally, the unit has two monitor outputs (**MONITOR+** and **MONITOR-**) to observe the optical input power level on each photodiode separately. Due to their increased cut-off frequency, these outputs can also be used to measure low frequency modulated signals on each detector separately.

The PDB4x5 Series is powered by an external linear power supply ( $\pm 12$  V, 250 mA - included) via a PICO M8 power connector.

Below is a functional block diagram of the PDB4x5 Series Balanced Amplified Photodetectors:

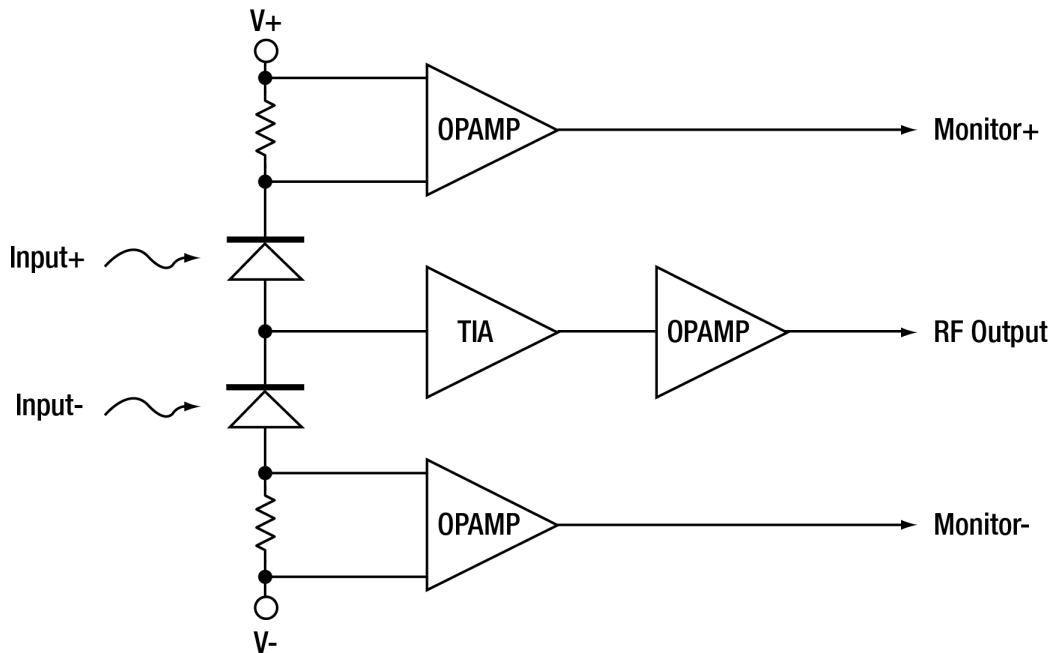

### 3.2 Optical Inputs

For all models except PDB435C and PDB465C, the fiber inputs are coupled to the photodiodes using two removable FC adapters. These FC receptacles accommodate either single-mode or multi-mode fiber with FC/PC or FC/APC connectors as well. PDB435C and PDB465C have also FC adapters, but they are **not removable**.

#### Attention

Be very careful about the force when connecting the fibers to the optical inputs! The photodiodes are mounted in such a way that the gap between the protective diode glass and the fiber tip is as small as possible. For this reason, **do not tighten** the fiber connector extremely in order to avoid damage to the glass window that protects the photodiode.

For all **PDB4x5C** models, the FC adapters are aligned for Corning SMF28™ single mode fiber with PC connectors. When using FC/APC connectors, minimal alignment errors may occur due to the small detector size, which will result in a reduced output signal. In such case, FC receptacle can be rotated from its original position in steps of 90° to check for an improved alignment. For this process use an optical input power below the saturation level while observing RF OUTPUT voltage on a digital voltmeter or other low-frequency measurement device. If you have an AC-coupled version, use either MONITOR output (CW signal) or RF OUTPUT (modulated optical signal) with connected oscilloscope for measurement.

In general, multi-mode fiber at the input can be used, but in this case the light beam spot diameter exceeds detector's active area, which results in a reduced output signal as well.

For free-space beam applications, it is recommended to remove FC adapter (receptacle) to have direct access to the photodiodes as shown below:

**Note**

FC adapters (receptacles) are **not** removable from PDB435C and PDB465C enclosures!

**Note**

Do not exceed a maximum power density of  $4 \text{ W/cm}^2$  for maximum linearity performance when measuring focused or small diameter beams. Always try to illuminate the whole detector active area to prevent nonlinearities. Equal power densities on both detectors are important for maximum common mode noise suppression (CMRR).

The PDB4x5 Series can be used in balanced mode (both inputs are illuminated) as well as in single detector mode. In single detector mode, the RF OUTPUT swing depends on which INPUT is used: it is positive for INPUT+ and negative for INPUT-.

In single detector mode, the optical input power should be below the specified CW saturation power (see [Technical Data](#)) to avoid saturation of the RF OUTPUT amplifier.

In balanced mode, the power difference between the optical inputs should be less than the CW Saturation Power. If necessary, use external neutral density filters or attenuators to reduce the input light level.

**Attention**

The optical damage threshold is 20 mW. Exceeding this value will permanently damage the photodiodes!

### 3.3 Electrical Outputs

The Thorlabs PDB4x5 Series has three SMA output connectors:

- **MONITOR +**
- **MONITOR -**
- **RF OUTPUT**

**RF OUTPUT** delivers an output voltage proportional to the difference between the photo currents of the two photodiodes. This voltage can be calculated by:

$$U_{\text{RF,OUT}} = (P_{\text{opt},1} - P_{\text{opt},2}) \times \mathfrak{R}(\lambda) \times G$$

with:  $\mathfrak{R}(\lambda)$  - responsivity of the photo diode at given wavelength

$P_{\text{opt},1}$  and  $P_{\text{opt},2}$  - optical input power

$G$  - transimpedance gain of the RF output

The responsivity  $\mathfrak{R}(\lambda)$  for a given wavelength can be read from the individual curves in section [Technical Data](#) to estimate the **RF OUTPUT** voltage. Please note that the given responsivity curves represent typical values - individual responsivity may deviate.

The maximum output voltage swing of the **RF OUTPUT** can be found in the [Technical Data](#) section.

The optical input saturation power (see the PDB4x5 Series individual technical data in the appendix) of the balanced detector is the minimum value, as it is given for the wavelength with the detector highest responsivity. At other wavelengths, saturation will be reached at higher input power levels. The output signal should not exceed the maximum output voltage to avoid saturation. Therefore the optical input power (or the power difference between the optical inputs) should not exceed CW Saturation Power listed in Specifications.

#### **MONITOR** Outputs

The signal monitor outputs (**MONITOR+** and **MONITOR-**) allow to observe the input power level and can be used as individual power indicators. These outputs can also be used to measure low frequency modulated signals on each detector separately. The maximum output voltage swing of the **MONITOR** output is +10 V for high impedance loads (+1.5 V into 50  $\Omega$ ). Saturation of **MONITOR** outputs will occur at optical input power level greater than 1 mW, depending on the detector's wavelength response.

**MONITOR** outputs can be used to roughly adjust equal input power levels on each detector for balanced operation. While the DC component of the **RF OUTPUT** in balanced mode is zero, the **MONITOR** outputs provide capability to independently observe the individual optical input power. **MONITOR** outputs of the unit are also convenient to use for free-space beam alignment.

The amplifier offset voltage is factory set to zero at 23°C ambient temperature. A small drift during a short warm-up period (~5min) may occur. For exact DC light level measurements a constant temperature environment is recommended.

### 3.4 Mounting

The PDB4x5 Series is housed in a rugged shielded aluminum enclosure.

For post mounting, an adapter can be attached to the bottom or side surface using four M2x8 screws (see below). This adapter supports #8-32 as well as M4 post mounts. The M4 thread is marked.

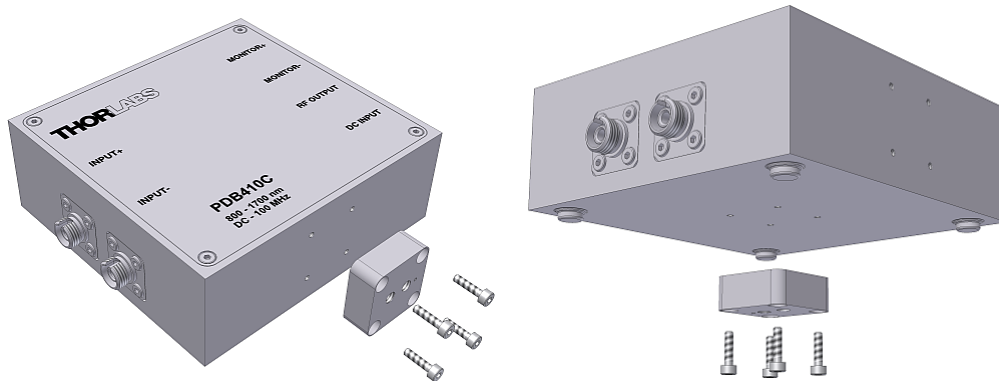

### 3.5 AC Coupling of the Outputs

In addition to the standard DC coupling of the **RF OUTPUT**, AC coupled versions for any model of PDB4x5 Series are available on request. AC coupling blocks the CW component (the unmodulated part) of the optical input signal. However, large CW components of the optical input signal will decrease linearity of the detectors.

AC coupling improves measurement capabilities in applications such as measuring a comparatively weak frequency modulated signal on a strong CW background signal, where the background signal is strong enough to potentially saturate the amplifier. With AC coupling, equalizing CW power levels on both inputs is not mandatory for noise cancellation. However, for optimal noise suppression the signal of interest (e.g. the modulated part) should be well balanced. AC coupling is also recommended when using the balanced detector in combination with a chopper and lock-in amplifier to further decrease noise level.

The lower cut-off frequency of the AC coupled versions is  $\leq 100$  Hz; typically below 5 Hz.

Please note that AC coupling slightly increases noise figures at lower frequencies. The measurement bandwidth of the RF OUTPUT is not affected by AC coupling.

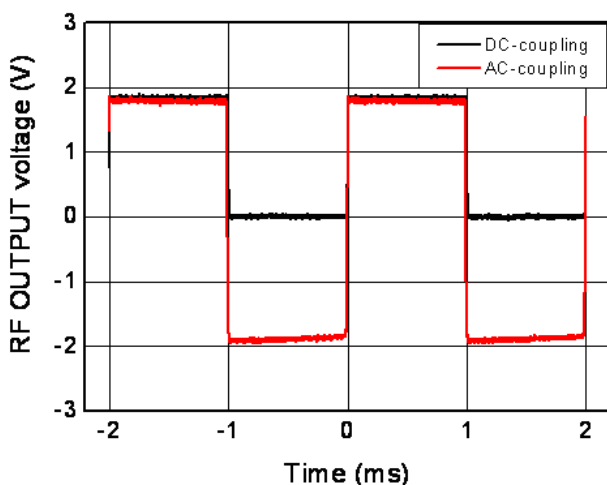

The figure to the left shows the comparison of AC and DC coupled RF Output signals when modulating the input signal with a mechanical chopper at a frequency of 500 Hz.

Note: Input signal for AC coupling was increased by factor 2 to allow direct waveform comparison.

### 3.6 CMRR and Frequency Response

An important specification for balanced amplifiers is the Common Mode Rejection Ratio (CMRR) that reflects the ability to suppress common mode noise.

In the setup as described below, the Device under Test (DuT) - here a PDB4x5 Series balanced detector - is tested for CMRR. A common mode signal is generated, which is canceled out when the amplifier is in balanced mode.

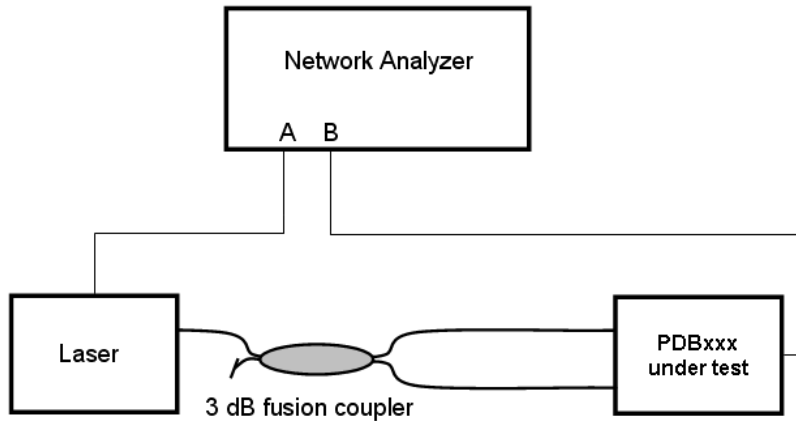

A network analyzer is used as signal generator (output A) and receiver (input B). The receiver is synchronized with the signal generator and measures selectively at the same frequency. A laser light source is modulated by the signal generator (port A) and acts as transmitter. To the laser output a 3 dB fusion coupler is connected, splitting the modulated light signal into two paths. Depending on the measurement task, one or both coupler outputs are connected to the inputs of the DuT, for example using S120-FC adapters. One of the DuT's outputs is connected to the network analyzer's Port B.

#### Frequency response measurements

The frequency response of each signal path can be measured by connecting only one coupler output to the appropriate input. This way, the frequency response curves of the RF OUTPUT from INPUT + and INPUT- can be measured, as well as the frequency responses of the MONITOR outputs, as shown in the individual technical data.

#### CMRR measurement

For Common Mode Rejection Ratio measurement, both outputs of the fusion coupler are connected to both inputs of the DuT. The optical power level at both inputs must be well matched ("balanced") in order to achieve the optimal common mode suppression. Now the common mode rejection can be measured as a function of frequency. The frequency response of the RF OUTPUT must be considered when calculating the CMRR - it is the difference between the RF OUTPUT signal at a given frequency and the measured common mode or balanced output signal - at the same frequency. Typical measurement curves can be found in the individual technical data.

### 3.7 Recommendations

Thorlabs PDB4x5 Series Balanced Amplified Photodetectors can eliminate noise sources to allow precise measurements. The PDB4x5 Series is designed to be used in a dual beam setup: one optical path for measurement and one invariant reference path. If set up properly, the PDB4x5 Series can reduce common mode noise for more than 35 dB over the specified frequency range. Below are given some recommendations to achieve an optimal common mode suppression:

- To obtain the maximum possible common mode rejection (common mode noise suppression), equal power levels on each photodetector are essential. Any power imbalance will be amplified and hence decrease the possible noise reduction.
- Equal power densities on both detectors are important as well to obtain maximum possible common mode rejection. Always try to illuminate the whole active area of the detectors to prevent nonlinearities. Focused high power beams may lead to frequency response degradation, resulting in dramatically reduced common mode rejection.
- Equal optical path lengths are very important for common mode noise suppression especially at higher frequencies. Any path length difference will introduce a phase difference between the two signals, which will decrease the noise reduction capability of the balanced detector. The figure below shows the maximum allowed path length difference in air to obtain a desired CMRR. For fiber based applications, the maximum path length difference must be divided by 1.5.

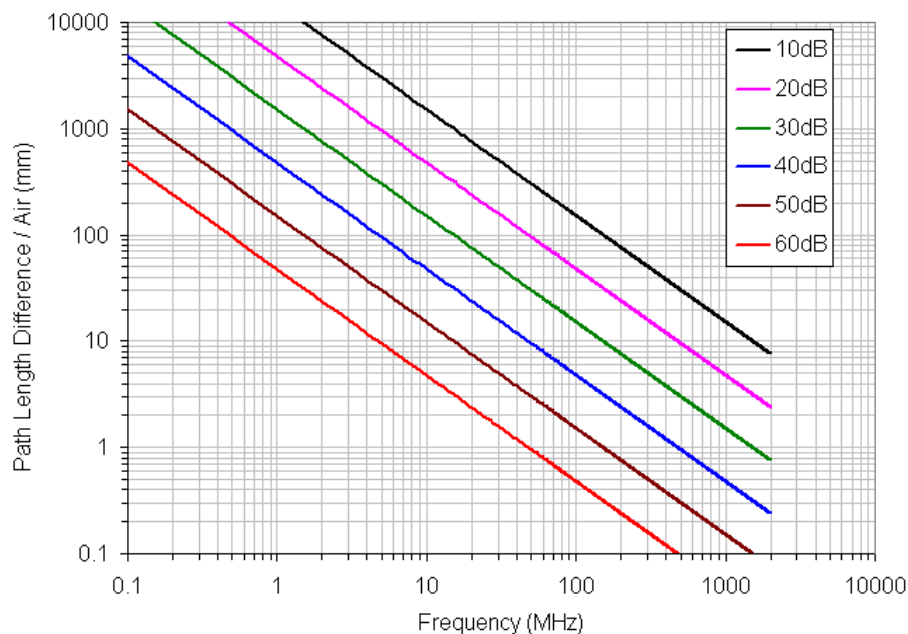

- Avoid etalon effects (interference fringes caused between two optical surfaces) in optical paths. Using angle polished optical connectors will greatly reduce etalon effects in a fiber based setup. Effects like residual frequency modulation, polarization noise, polarization wobble or spatial modulation can also degrade common mode noise suppression. For further details contact Thorlabs. In general, reducing sources of differential losses in the optical paths (other than the measurement itself) will improve the common mode noise reduction.
- Another critical point can be electrostatic coupling of electrical noise associated with ground loops. In most cases an electrically isolated post (see Thorlabs parts TRE or TRE/M) will suppress electrical noise coupling. Always try to identify the electrical noise sources and increase the distance to the PDB4x5 Series Balanced Detector. Different common ground points can also be tested.

## 4 Maintenance and Service

Protect the PDB4x5 Series from adverse weather conditions. The PDB4x5 Series is not water resistant.

### **Attention**

**Be very careful about the force used when connecting the fibers to the optical inputs! The photodiodes are mounted in such a way that the gap between the protective diode glass and the fiber tip is as small as possible. For this reason, do not tighten the fiber connector extremely in order to avoid damage to the glass window that protects the photodiode.**

### **Attention**

**To avoid damage to the instrument, do not expose it to spray, liquids or solvents!**

The unit does not need regular maintenance by the user. It does not contain any modules and/or components that could be repaired by the user. If a malfunction occurs, please contact [Thorlabs](#) for return instructions.

Do not remove covers!

To clean the PDB4x5 Series series housing, use a mild detergent and damp cloth. Do not soak the unit in water or use solvent based cleaners.

When cleaning the windows of the photodetectors, please remember that is a sensitive optical device. Gently blow off any debris using compressed air and wipe gently with an optic tissue wetted with isopropanol or alcohol.

## 5 Appendix

### Comments and explanations for individual specifications

- **Typical max. responsivity** is the peak responsivity  $\mathfrak{R}(\lambda)_{\max}$  of the photo diode.
- **Transimpedance Gain [V/A]** is the ratio of the output voltage to the photo current:

$$G_{\text{TI}} = \frac{U_{\text{RF, OUT}}}{I_{\text{PD}}} = \frac{U_{\text{RF, OUT}}}{P_{\text{IN}} \times \mathfrak{R}(\lambda)}$$

As the photo current depends on the wavelength, the transimpedance gain is wavelength-independent as well. The transimpedance gain values are always given for a high impedance load at the RF Output; for 50  $\Omega$  loads these values are divided by two.

- **Conversion Gain [V/W]** is the ratio of output voltage to input optical power:

$$G_{\text{CONV}} = \frac{U_{\text{RF, OUT}}}{P_{\text{IN}}} = G_{\text{TI}} \times \mathfrak{R}(\lambda)$$

This formula shows that the conversion gain is dependent on the actual wavelength, as well. In the specifications, the conversion gain is given only for the peak responsivity wavelength of the photo diode. The conversion gain values are always given for a high impedance load at the RF Output; for 50  $\Omega$  loads these values are divided by two.

- **NEP** (Noise Equivalent Power) is the minimum input optical power to generate a photo current, equal to the RMS noise current in a 1 Hz bandwidth. NEP is essentially the minimum detectable power. It is stated for the PDB4x5 Series balanced detectors from DC to the RF Output cutoff frequency.
- **Max. input power** is the damage threshold of the photo diode.
- **Typical noise spectra** (diagrams): These spectra were measured using an electrical spectrum analyzer (resolution bandwidth 100 kHz, video bandwidth 10 kHz unless otherwise noted). The INPUTs of the balanced detectors under test were blocked. The lower curve in the diagram was measured with the same setup and the balanced detectors under test switched off, i.e., it represents the measurement system's noise floor.
- **Monitor outputs** are designed for use with high impedance loads (e.g., high-Z scope input etc.), but can also drive 50  $\Omega$  loads. Monitor outputs conversion gain is 10 V/mW, given at the detectors' peak responsivity and high impedance load.
- **Typical frequency response curves** are measured using the setup described in section ["CMRR and Frequency Response"](#)

## 5.1 Technical Data

Common	
Optical Inputs	FC, removable (except PDB435C and PDB465C: <b>NOT removable</b> )
Max. Input Power (Damage Threshold)	20 mW
Electrical Outputs	SMA
RF OUTPUT	
Impedance	50 $\Omega$
Voltage Swing, max. (PDB415 / 425 / 435 / 465)	$\pm 3.6$ V <sup>1)</sup>
DC Offset	$< \pm 3$ mV
MONITOR Outputs	
Impedance	220 $\Omega$
Voltage Swing, max.	10 V (high impedance load); 1.55 V (50 $\Omega$ load)
Bandwidth	DC to 1 MHz
Conversion Gain	10 V/mW @ peak responsivity
Voltage Noise	$< 180$ $\mu$ V <sub>RMS</sub>
DC Offset	$< \pm 2$ mV
General	
Power Supply	$\pm 12$ V, 250mA
Dimensions	85 x 80x 30 mm <sup>3</sup>
Operating Temperature Range <sup>2)</sup>	0 - 40 °C
Storage Temperature Range	-40 to 70 °C
Weight	0.35 kg (w/o power supply)

<sup>1)</sup> Values are given for high impedance load. For a 50  $\Omega$  load, values are to be divided by 2.

<sup>2)</sup> Non-condensing

### Typical Detector responsivity curves

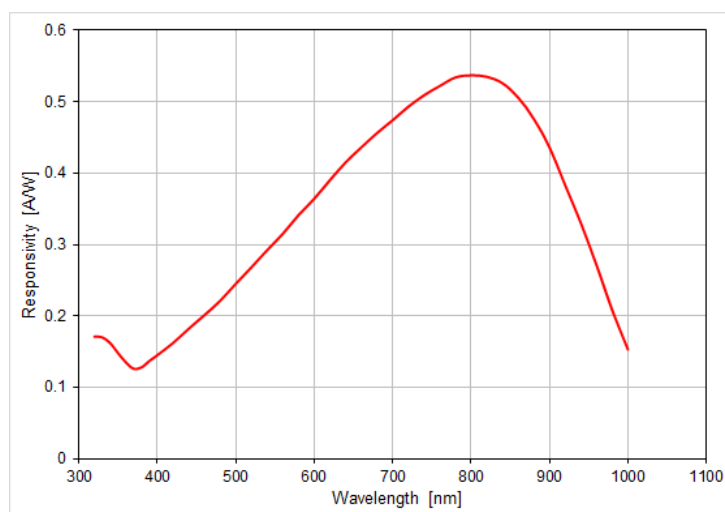

Typical Si Detector responsivity (PDB415A, PDB425A, PDB465A)

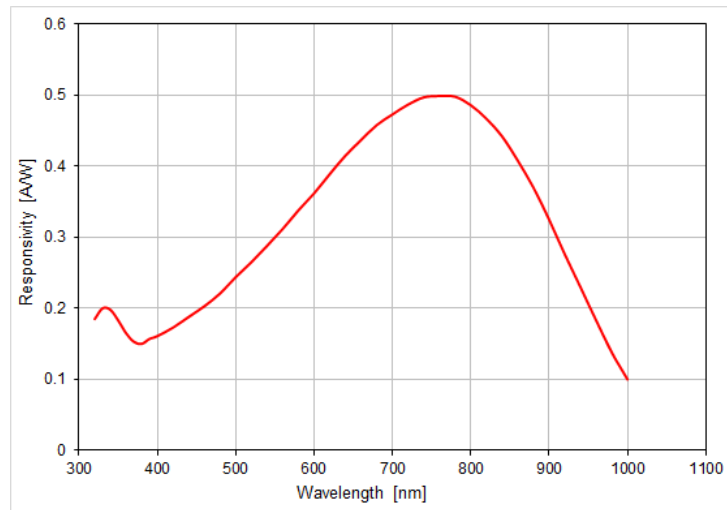

*Typical Si Detector responsivity (PDB435A)*

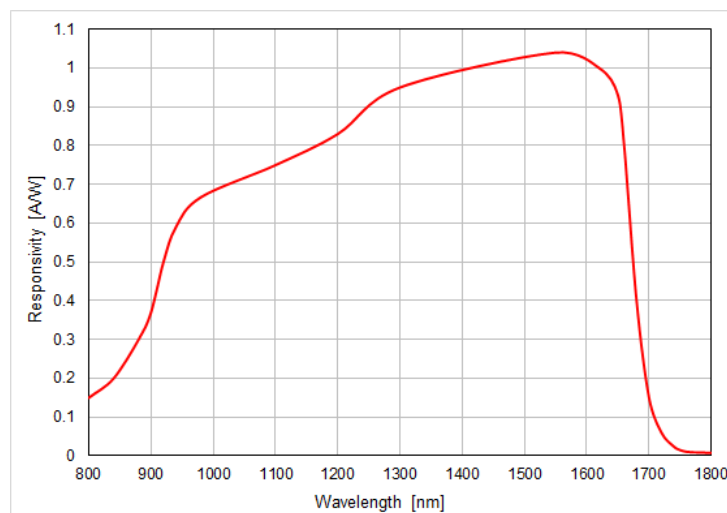

*Typical InGaAs Detector responsivity (PDB4x5C)*

### 5.1.1 PDB415x Individual Technical Data

	PDB415A	PDB415C
Detector Material / Type	Si / PIN	InGaAs / PIN
Operating Wavelength Range	320 - 1000 nm	800 - 1700 nm
Max. Responsivity, typ.	0.53 A/W	1.0 A/W
Detector Active Area Ø	0.8 mm	0.3 mm
RF OUTPUT Bandwidth (-3 dB)	DC - 100 MHz	
CMRR	>25 dB	
RF OUTPUT Transimpedance Gain <sup>1)</sup>	50 × 10 <sup>3</sup> V/A	
RF OUTPUT Conversion Gain <sup>2)</sup>	26.5 × 10 <sup>3</sup> V/W	50 × 10 <sup>3</sup> V/W
CW Saturation Power	135 µW @ 820 nm	72 µW @ 1550 nm
Minimum NEP (DC to 100 MHz)	12.03 pW/vHz	6.99 pW/vHz

<sup>1)</sup> Values are given for high impedance load. For a 50 Ω load, values are to be divided by 2.

<sup>2)</sup> Values are given at peak responsivity of the detector, for high impedance load. For a 50 Ω load, values are to be divided by 2.

## PDB415A

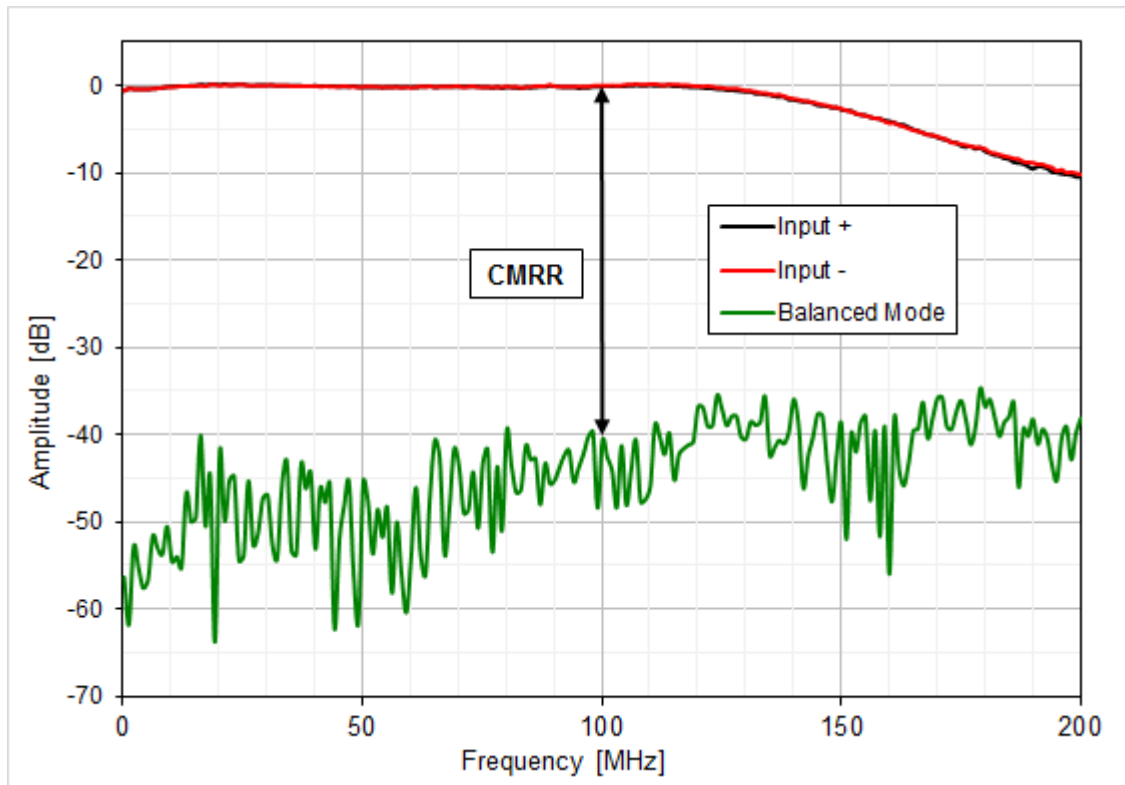
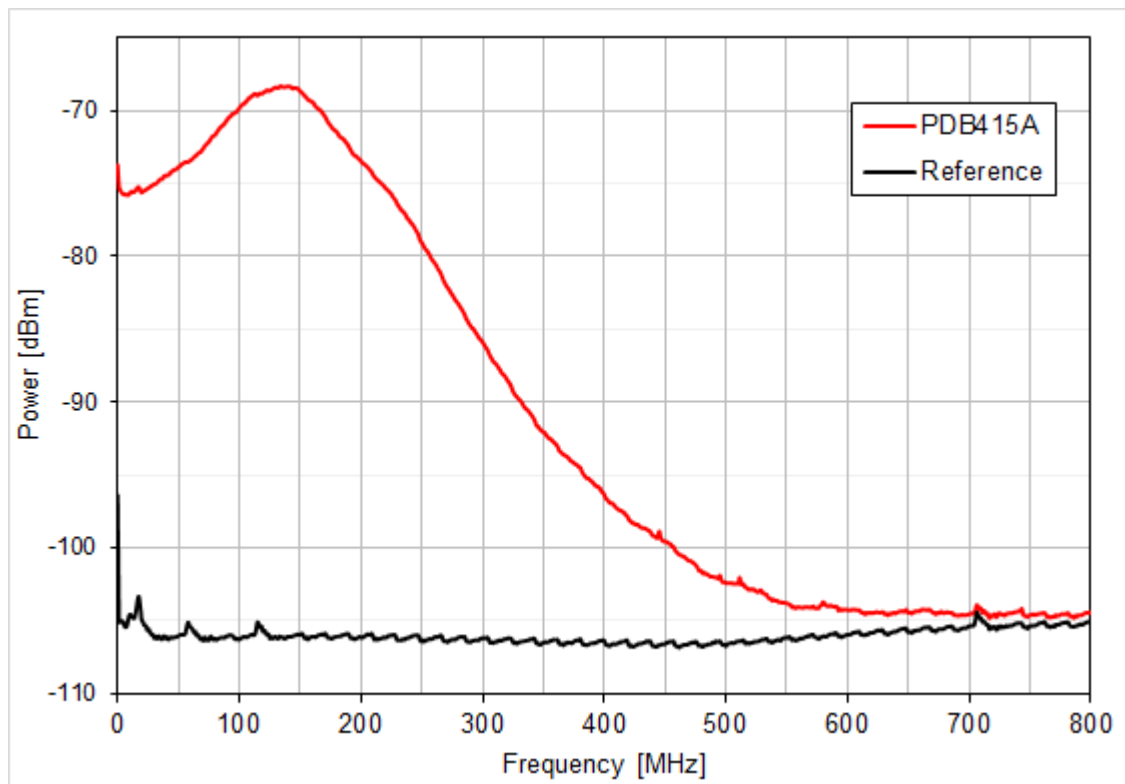
*PDB415A: Typical RF OUTPUT Frequency Response**PDB415A: RF OUTPUT Spectral Noise*

PDB415C

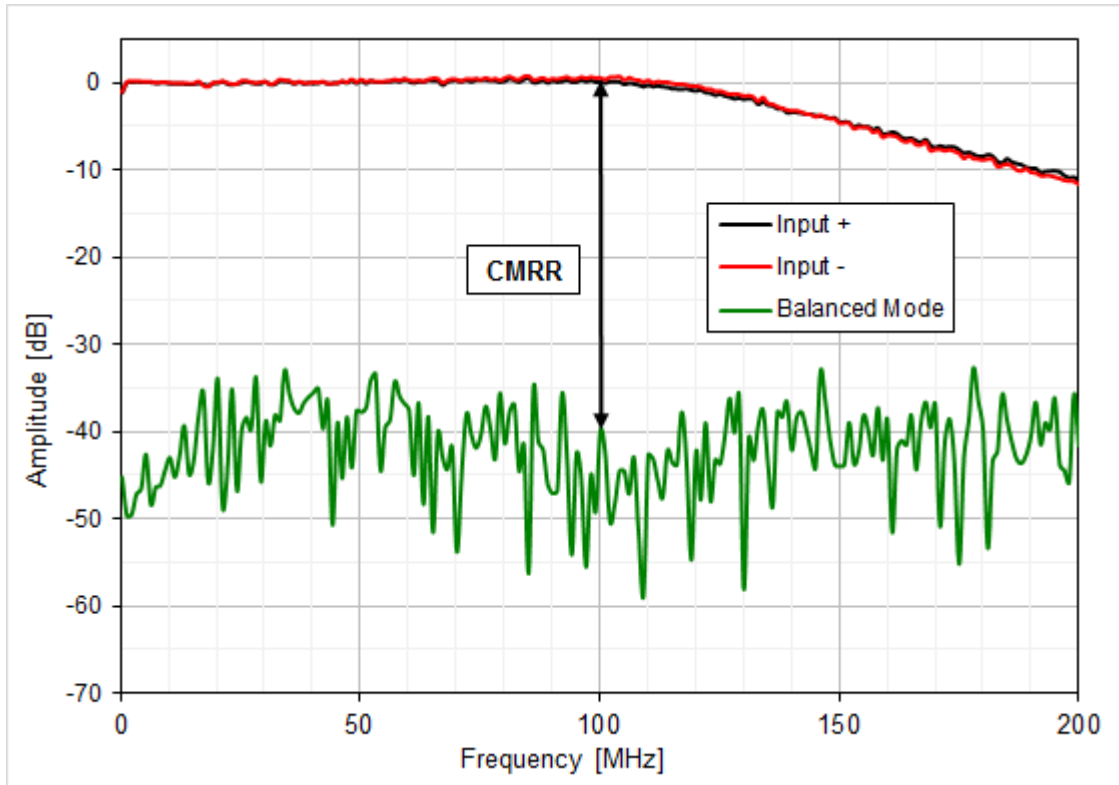

PDB415C: Typical RF OUTPUT Frequency Response

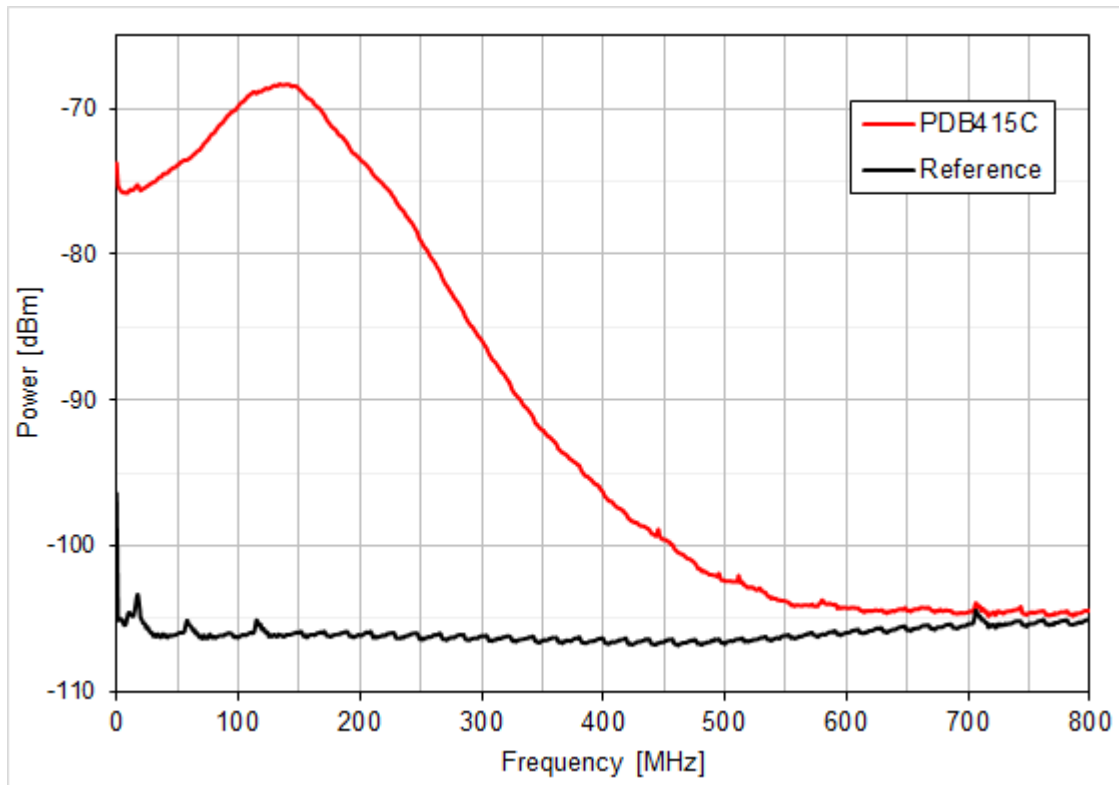

PDB415C: RF OUTPUT Spectral Noise

### 5.1.2 PDB425x Individual Technical Data

	PDB425A	PDB425C
Detector Material / Type	Si / PIN	InGaAs / PIN
Operating Wavelength Range	320 - 1000 nm	800 - 1700 nm
Max. Responsivity, typ.	0.53 A/W	1.0 A/W
Detector Active Area Ø	0.8 mm	0.3 mm
RF OUTPUT Bandwidth (-3 dB)	DC - 75 MHz	
CMRR	>35 dB	
RF OUTPUT Transimpedance Gain <sup>1)</sup>	250 × 10 <sup>3</sup> V/A	
RF OUTPUT Conversion Gain <sup>2)</sup>	133 × 10 <sup>3</sup> V/W	250 × 10 <sup>3</sup> V/W
CW Saturation Power	27 µW @ 820 nm	15 µW @ 1550 nm
Minimum NEP (DC to 75 MHz)	9.5 pW/vHz	5.2 pW/vHz

1) Values are given for high impedance load. For a 50 Ω load, values are to be divided by 2.

2) Values are given at peak responsivity of the detector, for high impedance load. For a 50 Ω load, values are to be divided by 2.

PDB425A

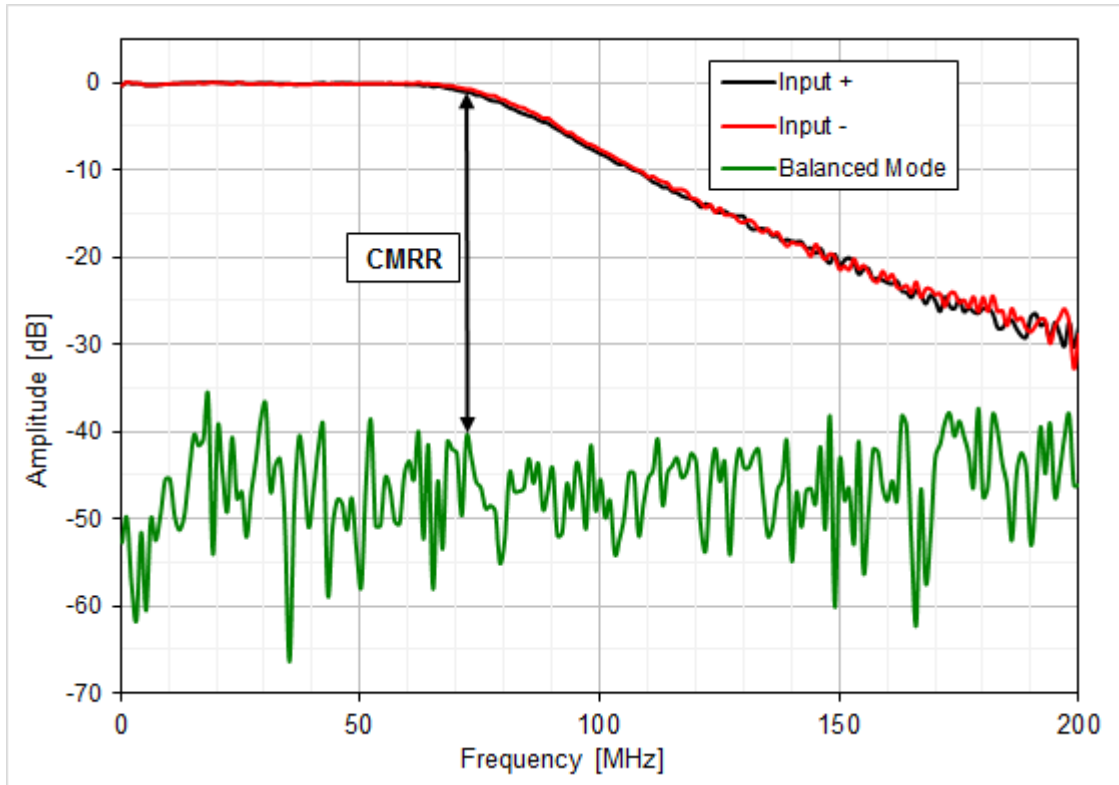

PDB425A: Typical RF OUTPUT Frequency Response

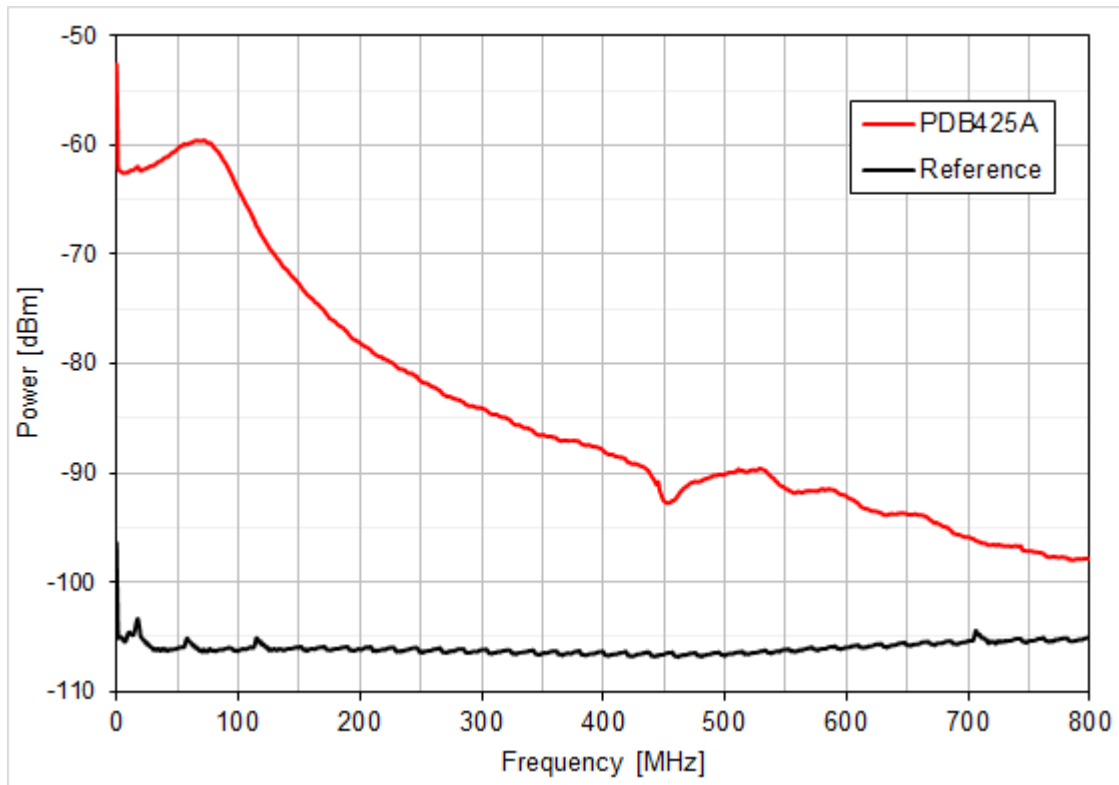

PDB425A: RF OUTPUT Spectral Noise

## PDB425C

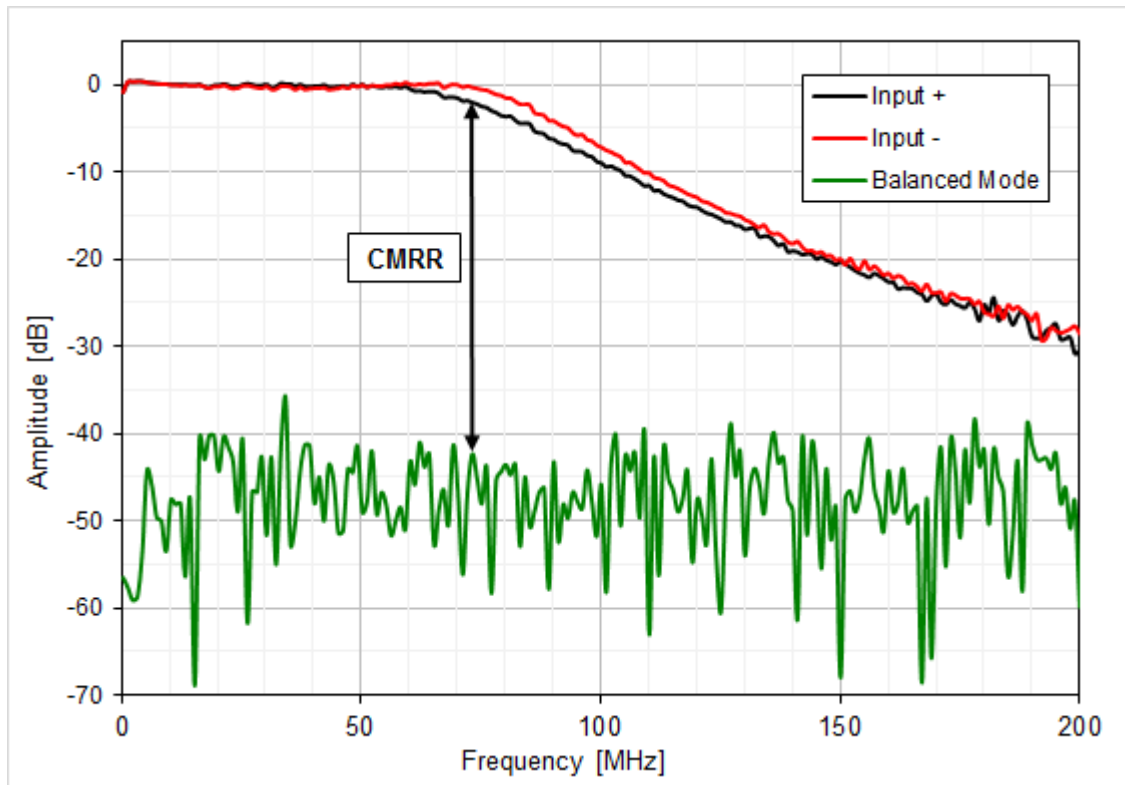
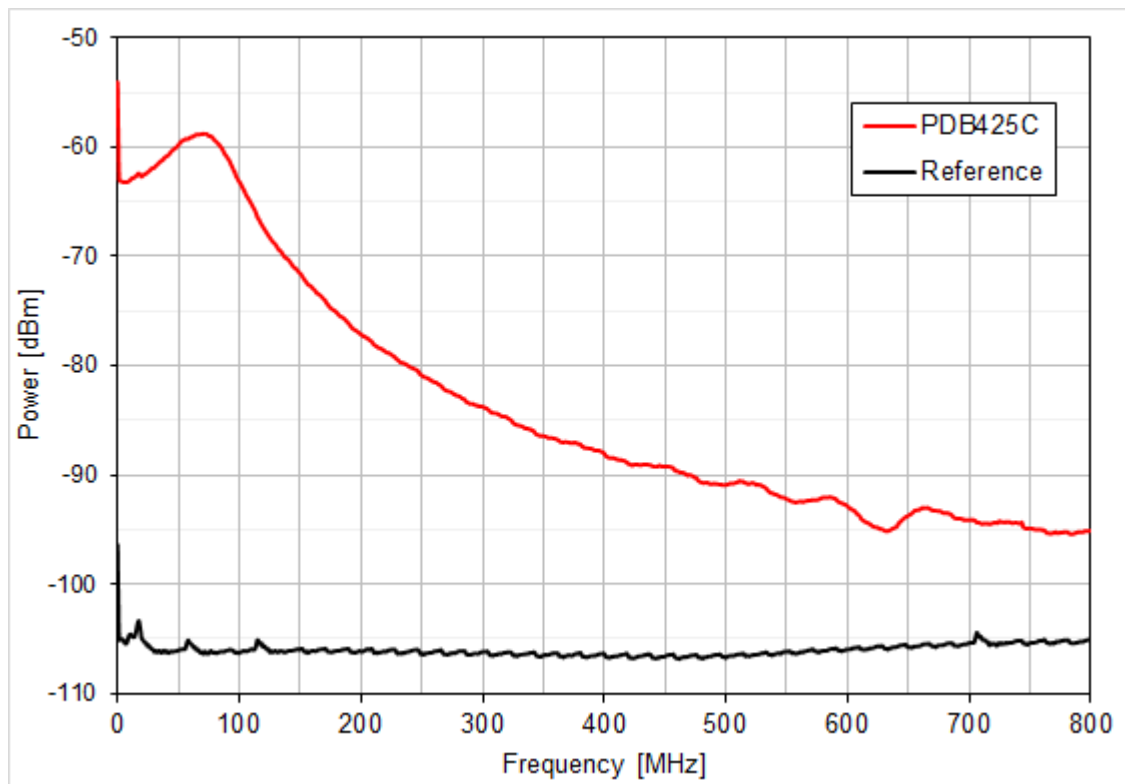
*PDB425C: Typical RF OUTPUT Frequency Response**PDB425C: RF OUTPUT Spectral Noise*

### 5.1.3 PDB435x Individual Technical Data

	PDB435A	PDB435C
Detector Material / Type	Si / PIN	InGaAs / PIN
Operating Wavelength Range	320 - 1000 nm	800 - 1700 nm
Max. Responsivity, typ.	0.5 A/W	1.0 A/W
Detector Active Area Ø	0.4 mm	0.15 mm
RF OUTPUT Bandwidth (-3 dB)	DC - 350 MHz	
CMRR	>20 dB	
RF OUTPUT Transimpedance Gain <sup>1)</sup>	$10 \times 10^3$ V/A	
RF OUTPUT Conversion Gain <sup>2)</sup>	$5 \times 10^3$ V/W	$10 \times 10^3$ V/W
CW Saturation Power	720 $\mu$ W @ 820 nm	360 $\mu$ W @ 1550 nm
Minimum NEP (DC to 350 MHz)	32.3 pW/vHz	15.28 pW/vHz

**Attention** PDB435C: FC receptacles are not removable!

- <sup>1)</sup> Values are given for high impedance load. For a 50  $\Omega$  load, values are to be divided by 2.
- <sup>2)</sup> Values are given at peak responsivity of the detector, for high impedance load. For a 50  $\Omega$  load, values are to be divided by 2.

## PDB435A

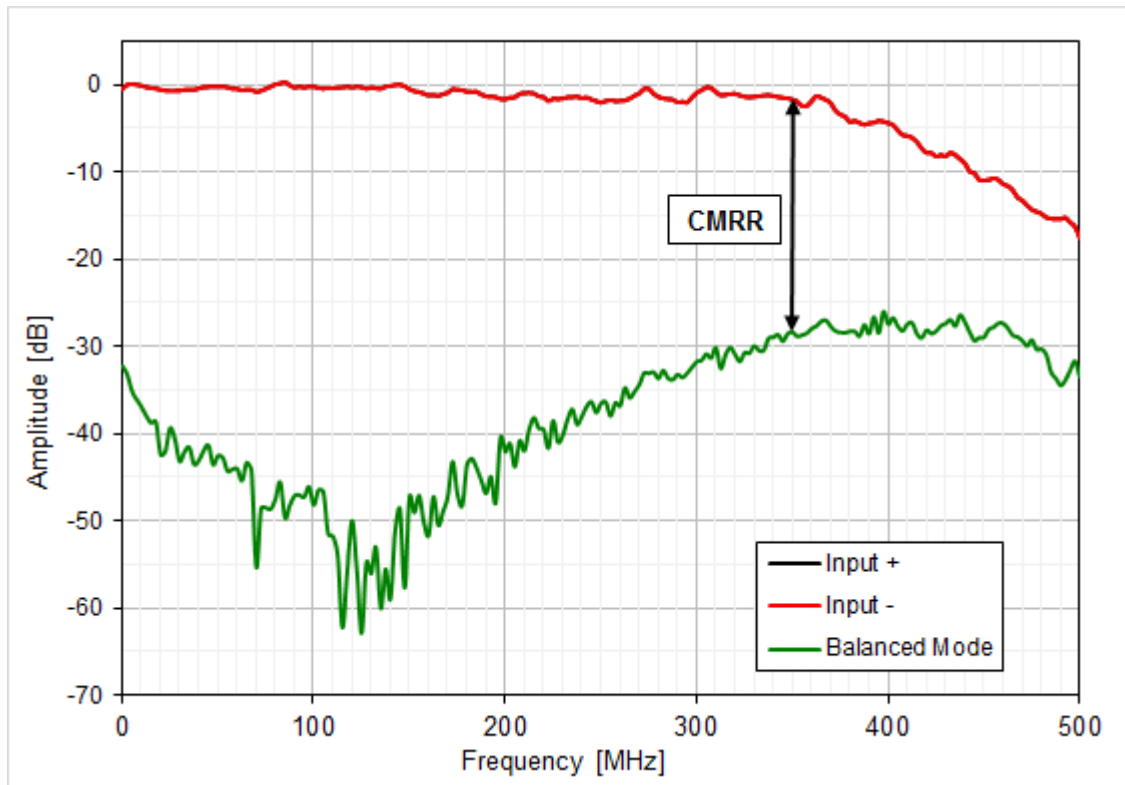
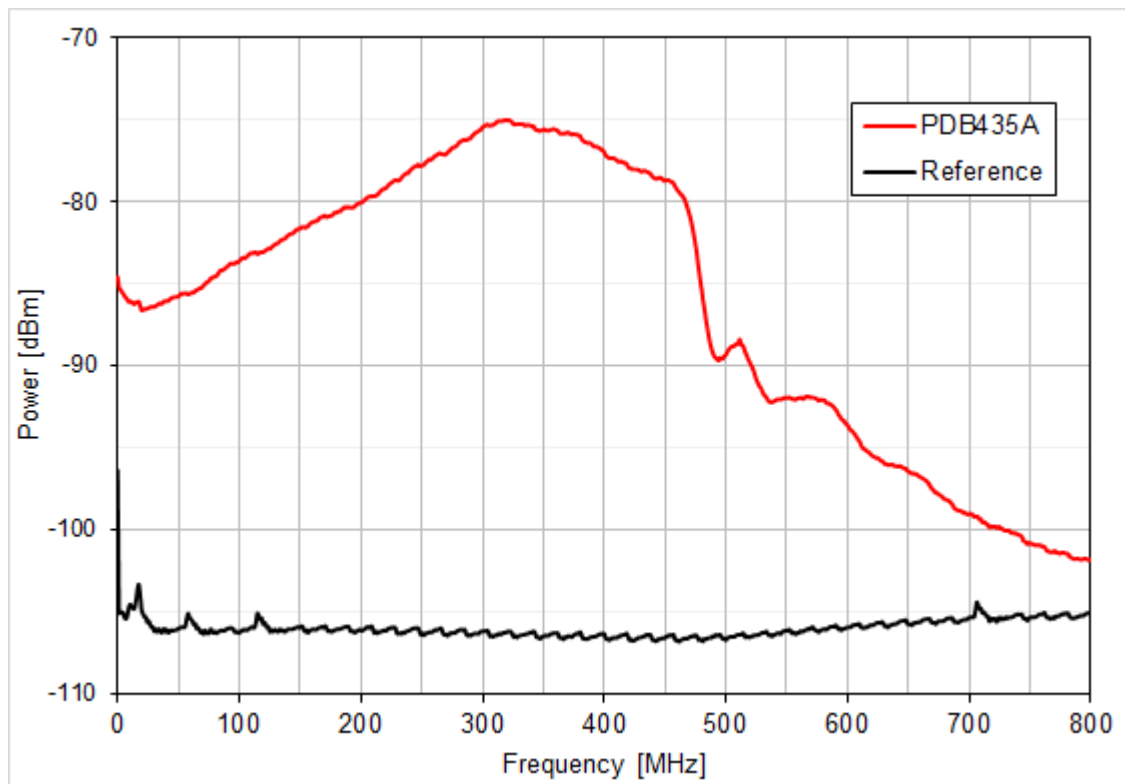
*PDB435A: Typical RF OUTPUT Frequency Response**PDB435A: RF OUTPUT Spectral Noise*

PDB435C

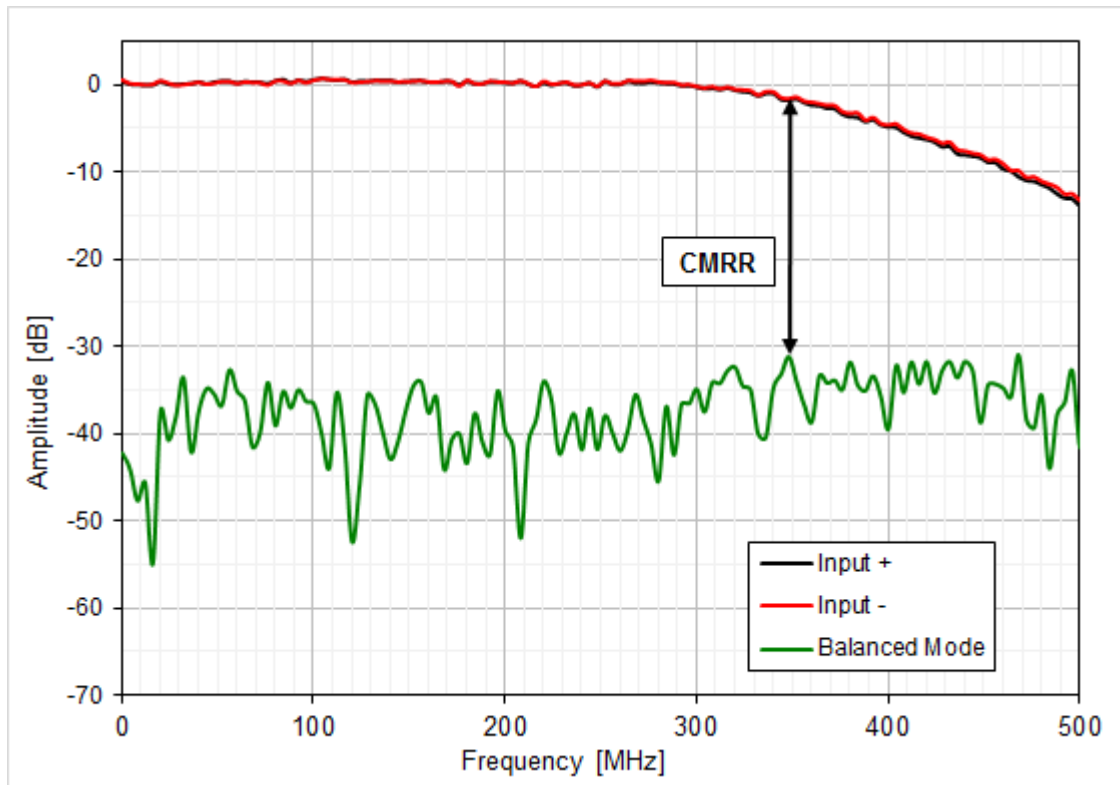

PDB435C: Typical RF OUTPUT Frequency Response

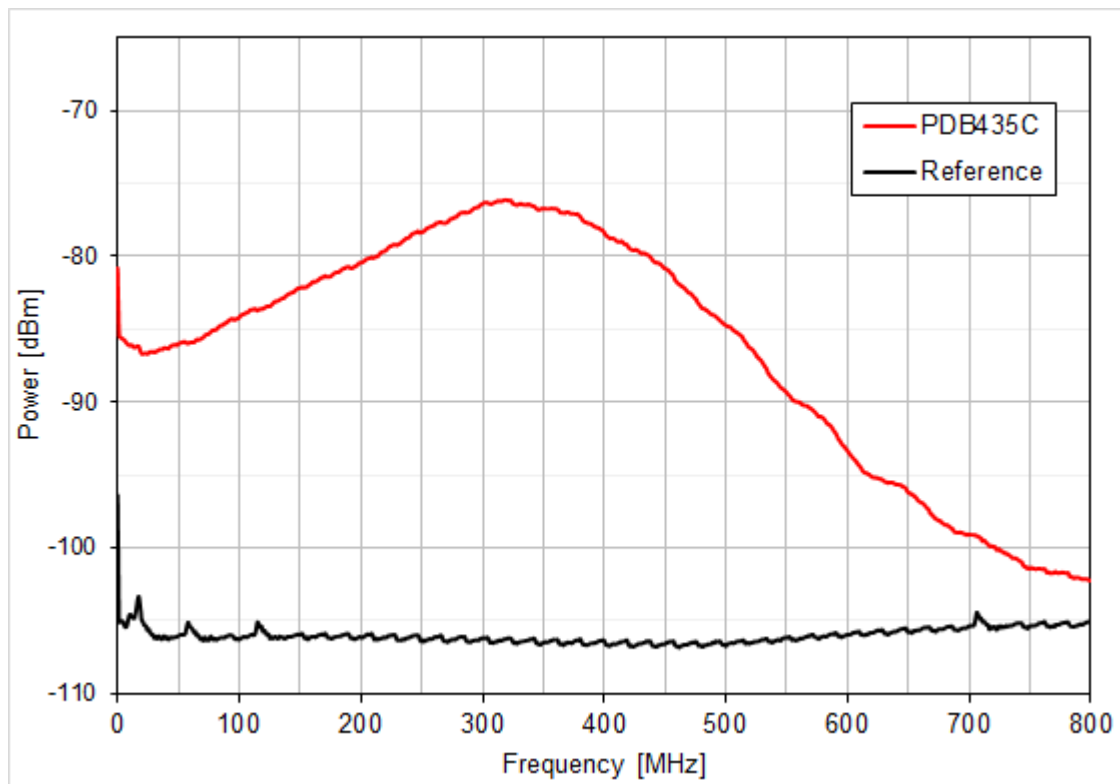

PDB435C: RF OUTPUT Spectral Noise

### 5.1.4 PDB465x Individual Technical Data

	PDB465A	PDB465C
Detector Material / Type	Si / PIN	InGaAs / PIN
Operating Wavelength Range	320 - 1000 nm	800 - 1700 nm
Max. Responsivity, typ.	0.50 A/W	1.0 A/W
Detector Active Area Ø	0.8 mm	0.15 mm
RF OUTPUT Bandwidth (-3 dB)	DC - 200 MHz	
CMRR	>25 dB	
RF OUTPUT Transimpedance Gain <sup>1)</sup>	$30 \times 10^3$ V/A	
RF OUTPUT Conversion Gain <sup>2)</sup>	$16 \times 10^3$ V/W	$30 \times 10^3$ V/W
CW Saturation Power	225 µW @ 820 nm	120 µW @ 1550 nm
Minimum NEP (DC to 200 MHz)	22.86 pW/vHz	8.52 pW/vHz

**Attention** PDB465C: FC receptacles are not removable!

- 1) Values are given for high impedance load. For a 50 Ω load, values are to be divided by 2.
- 2) Values are given at peak responsivity of the detector, for high impedance load. For a 50 Ω load, values are to be divided by 2.

PDB465A

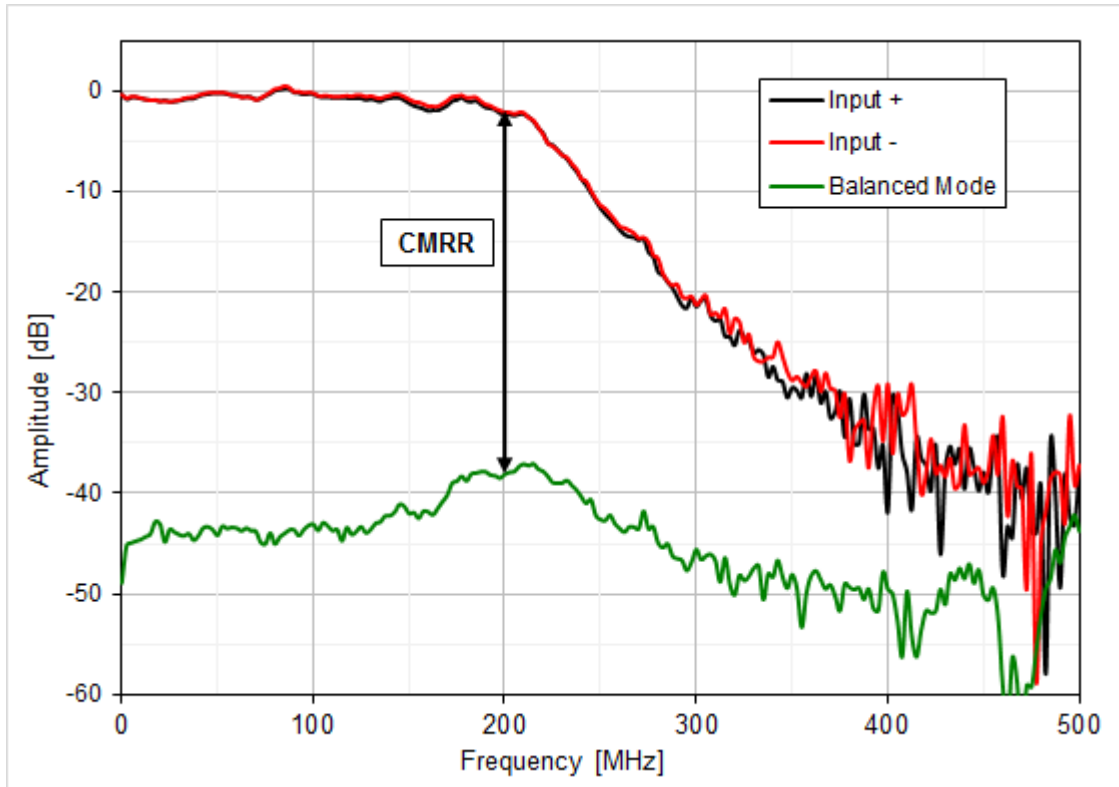

PDB465A: Typical RF OUTPUT Frequency Response

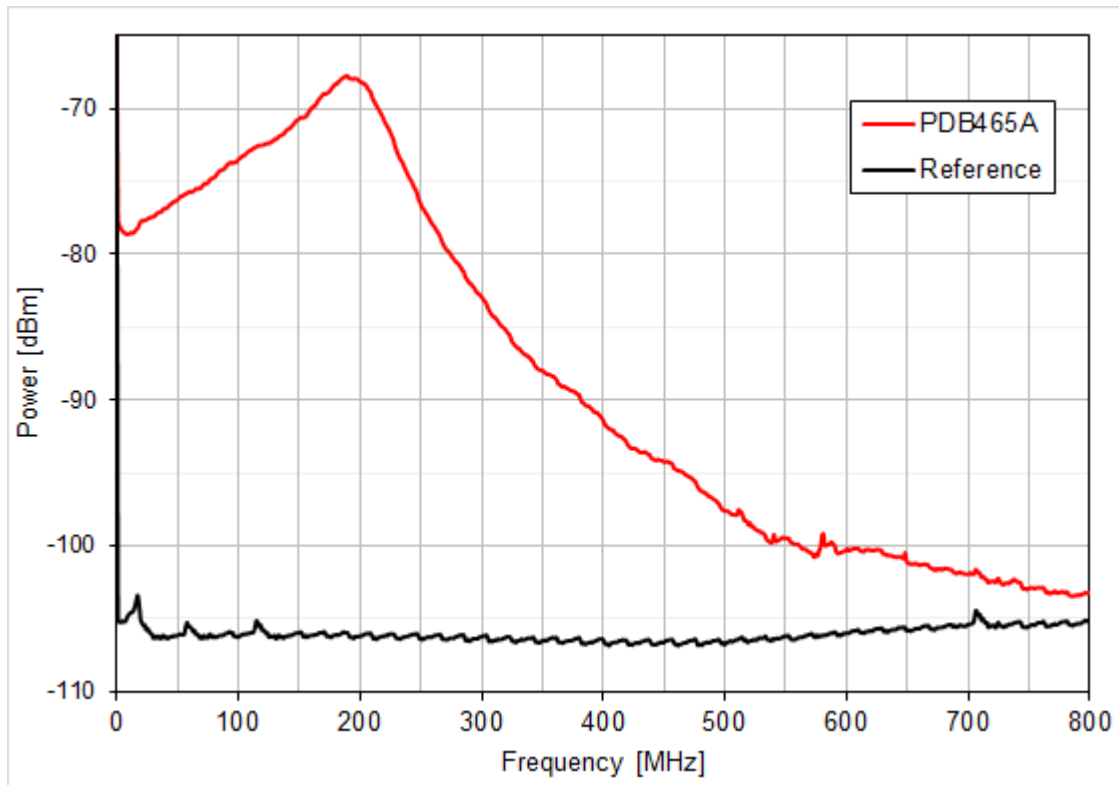

PDB465A: RF OUTPUT Spectral Noise

## PDB465C

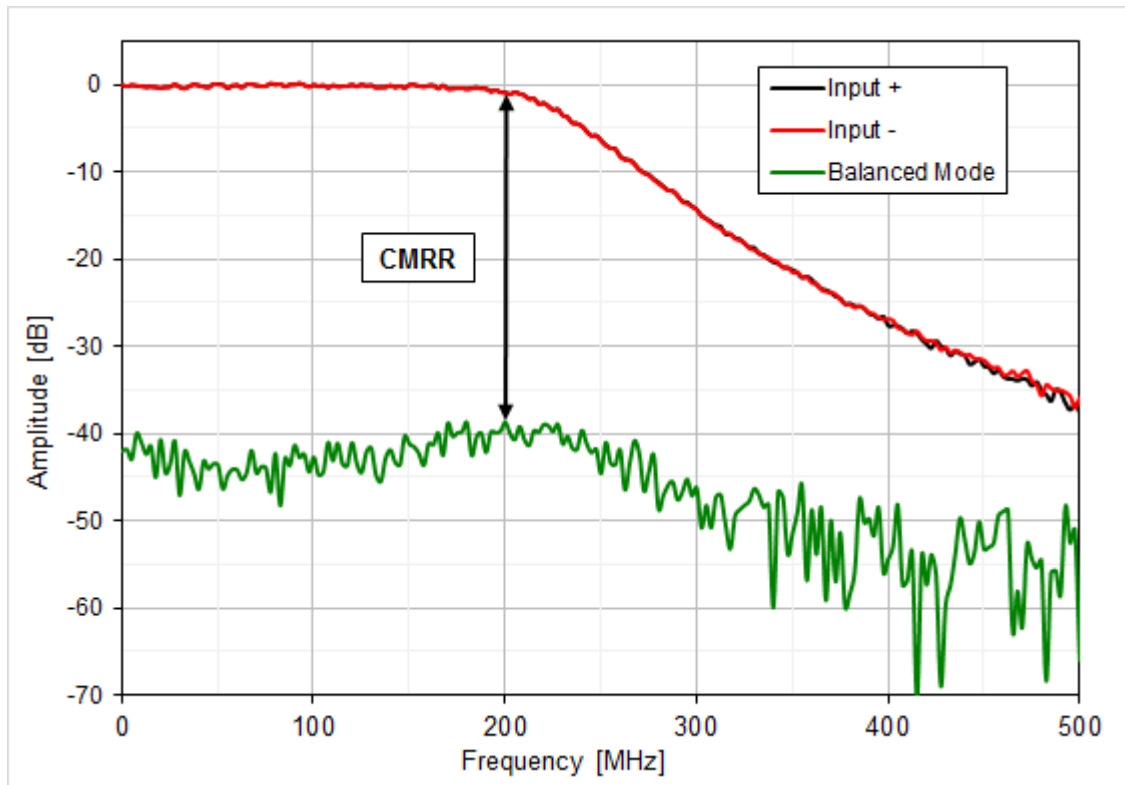
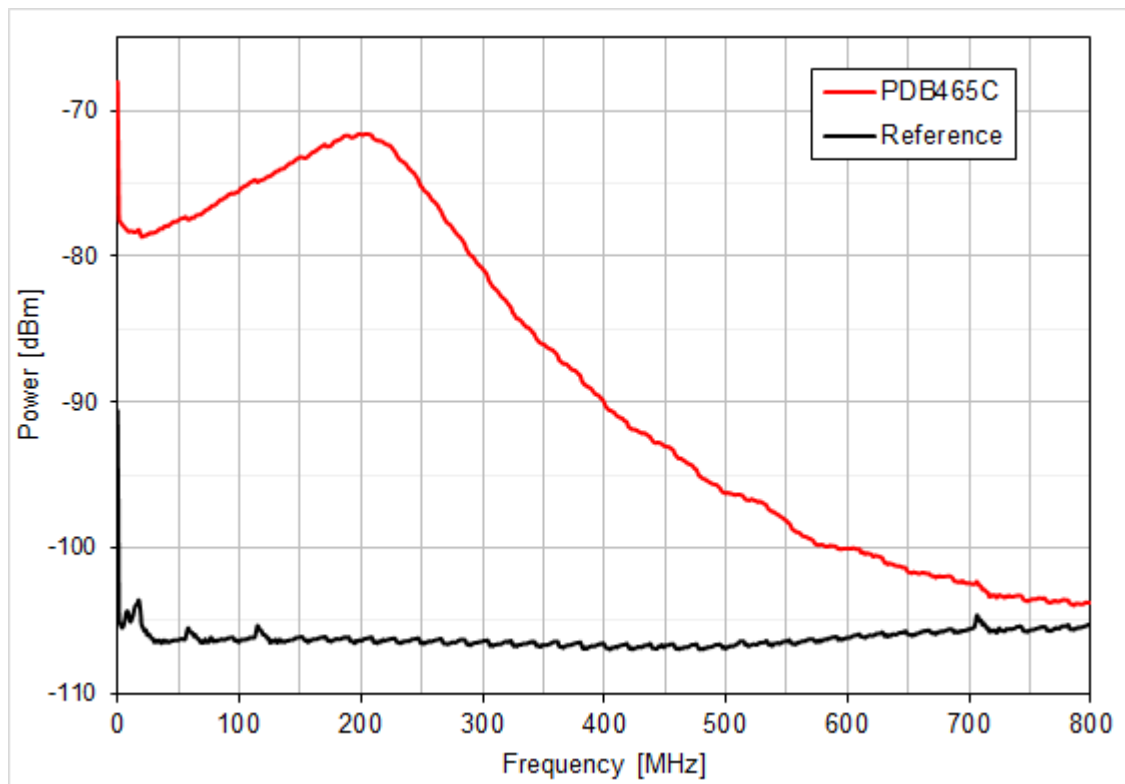
*PDB465C: Typical RF OUTPUT Frequency Response**PDB465C: RF OUTPUT Spectral Noise*

## 5.2 Dimensions

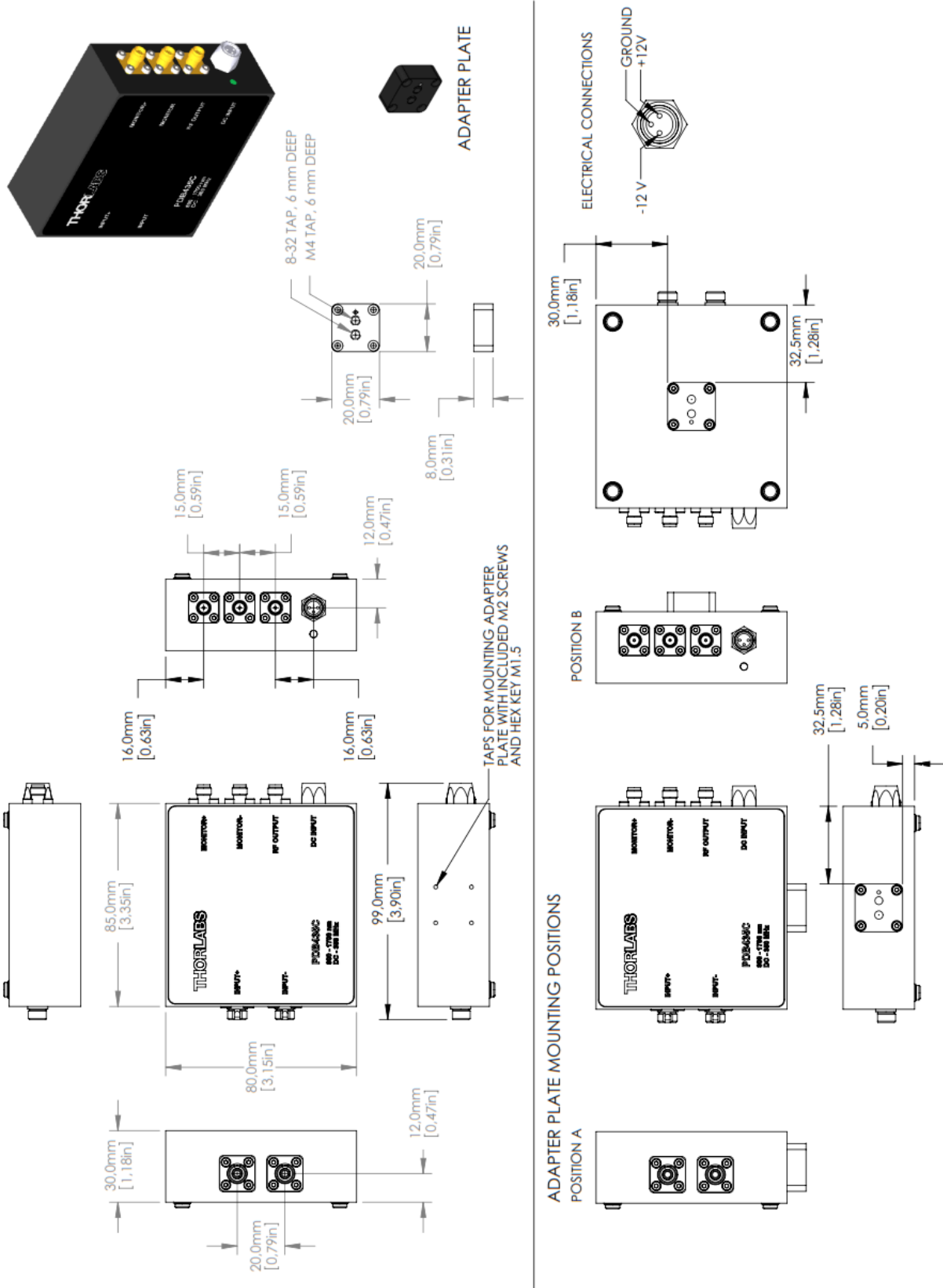

Mechanical Drawing PDB415, PDB425, PDB435 and PDB465C

## 5.3 Certifications and Compliances

<i>EU Declaration of Conformity</i>		
<i>in accordance with EN ISO 17050-1:2010</i>		
<b>We:</b>	Thorlabs GmbH	
<b>Of:</b>	Münchner Weg 1, 85232 Bergkirchen, Deutschland	
<i>in accordance with the following Directive(s):</i>		
2014/35/EU	Low Voltage Directive (LVD)	
2014/30/EU	Electromagnetic Compatibility (EMC) Directive	
2011/65/EU	Restriction of Use of Certain Hazardous Substances (RoHS)	
<i>hereby declare that:</i>		
<b>Model:</b>	<i>PDB2*, PDB4*, PDB5*, PDB8*</i>	
<b>Equipment:</b>	<i>Fixed and switchable gain balanced amplifiers</i>	
<i>is/are in conformity with the applicable requirements of the following documents:</i>		
EN 61010-1	Safety Requirements for Electrical Equipment for Measurement, Control and Laboratory Use.	2010 + A1:2019 + AC:2019.
EN 61326-1	Electrical Equipment for Measurement, Control and Laboratory Use - EMC Requirements	2013
<i>and which, issued under the sole responsibility of Thorlabs, is/are in conformity with Directive 2011/65/EU of the European Parliament and of the Council of 8th June 2011 on the restriction of the use of certain hazardous substances in electrical and electronic equipment, for the reason stated below:</i>		
contains no substances in excess of the maximum concentration values tolerated by weight in homogenous materials as listed in Annex II of the Directive		
<i>I hereby declare that the equipment named has been designed to comply with the relevant sections of the above referenced specifications, and complies with all applicable Essential Requirements of the Directives.</i>		
<b>Signed:</b>		<b>On:</b> 29 November 2022
<b>Name:</b>	Dr. Bruno Gross	
<b>Position:</b>	General Manager	
		<b>CE</b>
		<small>EDC - PDB2*, PDB4*, PDB5*, PDB8'</small>

## 5.4 Warranty

Thorlabs warrants material and production of the PDB4x5 Series for a period of 24 months starting with the date of shipment in accordance with and subject to the terms and conditions set forth in Thorlabs' General Terms and Conditions of Sale which can be found at:

General Terms and Conditions:

[https://www.thorlabs.com/Images/PDF/LG-PO-001\\_Thorlabs\\_terms\\_and\\_%20agreements.pdf](https://www.thorlabs.com/Images/PDF/LG-PO-001_Thorlabs_terms_and_%20agreements.pdf)

and

[https://www.thorlabs.com/images/PDF/Terms%20and%20Conditions%20of%20Sales\\_Thorlabs-GmbH\\_English.pdf](https://www.thorlabs.com/images/PDF/Terms%20and%20Conditions%20of%20Sales_Thorlabs-GmbH_English.pdf)

## 5.5 Copyright and Exclusion of Liability

Thorlabs has taken every possible care in preparing this document. We however assume no liability for the content, completeness or quality of the information contained therein. The content of this document is regularly updated and adapted to reflect the current status of the product.

All rights reserved. This document may not be reproduced, transmitted or translated to another language, either as a whole or in parts, without the prior written permission of Thorlabs. Copyright © Thorlabs 2023. All rights reserved.

Please refer to the general terms and conditions linked under [Warranty](#).

## 5.6 Thorlabs Worldwide Contacts

For technical support or sales inquiries, please visit us at <https://www.thorlabs.com/locations.cfm> for our most up-to-date contact information.



### USA, Canada, and South America

Thorlabs, Inc.  
sales@thorlabs.com  
techsupport@thorlabs.com

### UK and Ireland

Thorlabs Ltd.  
sales.uk@thorlabs.com  
techsupport.uk@thorlabs.com

### Europe

Thorlabs GmbH  
europe@thorlabs.com

### Scandinavia

Thorlabs Sweden AB  
scandinavia@thorlabs.com

### France

Thorlabs SAS  
sales.fr@thorlabs.com

### Brazil

Thorlabs Vendas de Fotônicos Ltda.  
brasil@thorlabs.com

### Japan

Thorlabs Japan, Inc.  
sales@thorlabs.jp

### China

Thorlabs China  
chinasales@thorlabs.com

### Thorlabs 'End of Life' Policy (WEEE)

Thorlabs verifies our compliance with the WEEE (Waste Electrical and Electronic Equipment) directive of the European Community and the corresponding national laws. Accordingly, all end users in the EC may return "end of life" Annex I category electrical and electronic equipment sold after August 13, 2005 to Thorlabs, without incurring disposal charges. Eligible units are marked with the crossed out "wheelie bin" logo (see right), were sold to and are currently owned by a company or institute within the EC, and are not disassembled or contaminated. Contact Thorlabs for more information. Waste treatment is your own responsibility. "End of life" units must be returned to Thorlabs or handed to a company specializing in waste recovery. Do not dispose of the unit in a litter bin or at a public waste disposal site. It is the users responsibility to delete all private data stored on the device prior to disposal.

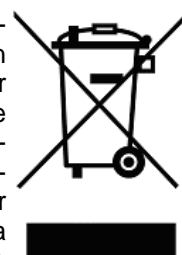



**THORLABS**

[www.thorlabs.com](http://www.thorlabs.com)

---