



Balanced Amplified Photodetectors

**PDB480C-AC, PDB481C-AC,
PDB482C-AC**

Operation Manual



2023

Version: 1.8
Date: 31-Aug-2023

Contents

1	Intended Use	2
2	General Information	3
2.1	Ordering Codes and Accessories _____	3
3	Installation	4
3.1	Parts List _____	4
3.2	Getting Started _____	4
4	Operating Instructions	5
4.1	Operating Principle _____	5
4.2	Optical Inputs _____	6
4.3	Electrical Outputs _____	6
4.4	Mounting _____	7
4.5	CMRR and Frequency Response _____	8
4.6	Recommendations _____	9
5	Maintenance and Service	10
6	Appendix	11
6.1	Technical Data _____	12
6.1.1	Individual Diagrams PDB480C-AC _____	13
6.1.2	Individual Diagrams PDB481C-AC _____	15
6.1.3	Individual Diagrams PDB482C-AC _____	17
6.2	Dimensions _____	19
6.3	Safety _____	20
6.4	Certifications and Compliances _____	21
6.5	Warranty _____	22
6.6	Return of Devices _____	22
6.7	Manufacturer Address _____	22
6.8	Copyright and Exclusion of Liability _____	22
6.9	Thorlabs Worldwide Contacts and WEEE Policy _____	23

1 Intended Use

The PDB48xC-AC Balanced Amplified Photodetectors act as a balanced receiver by subtracting the two optical input signals from each other, resulting in the cancellation of common mode noise. This allows small changes in the signal path to be extracted from the interfering noise floor. It is used in photonics research and development applications.

The PDB48xC-AC Balanced Amplified Photodetectors are designed for laboratory use only. These products may not be used or integrated into equipment that is applied in pharmaceutical, medical or military applications.

Thorlabs, Inc. Life Support and Military Use Application Policy is stated below:

THORLABS' PRODUCTS ARE NOT AUTHORIZED FOR USE AS CRITICAL COMPONENTS IN LIFE SUPPORT DEVICES OR SYSTEMS OR IN ANY MILITARY APPLICATION WITHOUT THE EXPRESS WRITTEN APPROVAL OF THE PRESIDENT OF THORLABS, INC. As used herein:

1. Life support devices or systems are devices or systems which, (a) are intended for surgical implant into the body, or (b) support or sustain life, and whose failure to perform, when properly used in accordance with instructions for use provided in the labeling, can be reasonably expected to result in a significant injury to the user.
2. A critical component is any component in a life support device or system whose failure to perform can be reasonably expected to cause the failure of the life support device or system or to affect its safety or effectiveness.
3. The Thorlabs products described in this document are not intended nor warranted for usage in Military Applications.

2 General Information

Thorlabs PDB48xC(-AC) Balanced Amplified Photodetectors consist of two well-matched, fiber coupled photodiodes with length matched fibers and an ultra-low noise, ultra-low distortion high-speed transimpedance amplifier that generates an output voltage (RF OUTPUT) proportional to the difference between the photo current in the two photodiodes, i.e. the two optical input signals. Additionally, the unit has two fast monitor outputs (MONITOR+ and MONITOR-) to measure the individual optical input power level as well as low frequency (up to 3 MHz) modulated signals on each detector separately.

An adapter for post mounting can be attached to the bottom or side surface of the PDB48xC(-AC) housing. This adapter supports #8-32 as well as M4 post mounts.

The PDB48xC(-AC) is supplied with an external linear power supply.

The [“Getting Started”](#) ⁴ section gives an overview of how to set up the PDB48xC(-AC) Balanced Amplified Photodetectors. Subsequent sections contain detailed information about principle of operation, operating suggestions and technical specifications.

2.1 Ordering Codes and Accessories

- PDB480C-AC** 1.6 GHz, Fixed Gain, Ultra-Low Distortion Balanced Amplified Photodetector with Fiber Length Matched Pigtailed InGaAs Photo Diodes, Fiber SMF28
- PDB481C-AC** 1.0 GHz, Fixed Gain, Ultra-Low Distortion Balanced Amplified Photodetector with Fiber Length Matched Pigtailed InGaAs Photo Diodes, Fiber HI1060
- PDB482C-AC** 2.5 GHz, Fixed Gain, Ultra-Low Distortion Balanced Amplified Photodetector with Fiber Length Matched Pigtailed InGaAs Photo Diodes, Fiber HI1060

3 Installation

This section is intended to provide information how to set up quickly the PDB48xC(-AC) Balanced Amplified Photodetectors. More details and advanced features are described in the chapter [Operating Instructions](#) of the full manual.

3.1 Parts List

Please inspect the shipping container for damage. Please do not cut through the cardboard. You might need the box for storage or for returns.

If the shipping container seems to be damaged, keep it until you have inspected the contents and you have inspected the PDB48xC(-AC) mechanically and electrically.

Verify that you have received the following items within the package:

1. PDB48xC(-AC) Balanced Amplified Photodetector
2. Adapter Plate with four M2x8 screws and a hex key 1.5, for post-mounting on an optical table
3. [LDS12B](#) power supply (± 12 V, 250 mA), switchable to 100 V, 120 V, or 230 V line voltage
4. Quick Reference

3.2 Getting Started

Note

Please check prior to operation, if the indicated line voltage range on the power supply matches with your local mains voltage! If you want use your own power supply, Thorlabs offers an appropriate power connector cable.

- Carefully unpack the unit and accessories. If any damage is noticed, do not use the unit. Contact [Thorlabs](#) and have us replace the defective unit.
- If required, mount the unit on your optical table or application. Therefore, mount the adapter plate on bottom or side wall using the four M2x8 screws first. The adapter plate has two mounting holes, M4 and #8-32. The M4 thread is marked. These threads can be used for mounting onto Thorlabs posts.
- Set the power supply to your local mains voltage (100, 120, or 230 VAC):



Voltage Selector Switch

- Connect the DC output cable of the power supply to the POWER IN jack.
- Connect the power supply to the AC outlet and turn the power supply on.
- Connect RF OUTPUT with coaxial cable to the data acquisition device. Please note, that a 50 Ω impedance device should be used for best RF performance.
- If necessary, connect monitor outputs (MONITOR+, MONITOR-) to measure the optical input power for each channel individually.

4 Operating Instructions

- Turn the power switch of the power supply to I. The green LED next to the DC input connector indicates correct power supply.
- Connect the optical source(s) to the optical input(s). Please note that the PDB48xC(-AC) is designed for FC/APC connectors!
- MONITOR outputs can be used for convenient alignment of a coarse input power balance. The maximum output voltage swing of the MONITOR outputs is 10V for high impedance loads. Saturation of the MONITOR outputs will occur at optical input power greater than 1 mW.
- The RF output signal must not exceed the maximum RF OUTPUT power at 1 dB compression (see [Technical Data](#)^[12]) to avoid saturation.
- For balanced operation illuminate both photodiodes simultaneously and use the MONITOR outputs to fine-tune the optical power balance by observing voltage on a digital voltmeter or other low-frequency measurement device.
- After finishing measurements, turn power off.

Attention

The damage threshold of the photo diodes is 10 mW (PDB480C-AC) resp. 5 mW (PDB481C-AC and PDB482C-AC)! Exceeding this value will permanently destroy the detector!

4.1 Operating Principle

Thorlabs PDB48xC(-AC) Balanced Amplified Photodetectors consist of two well-matched, pigtailed photodiodes and an ultra-low noise, ultra-low distortion high-speed transimpedance amplifier that generates an output voltage (**RF OUTPUT**) proportional to the difference between the photo currents of the two photodiodes, i.e. the difference between the two optical input signals.

Additionally, the units have two monitor outputs (**MONITOR+** and **MONITOR-**) to observe the optical input power level on each photodiode separately. Due to their increased cut-off frequency, these outputs can also be used to measure low frequency modulated signals on each detector separately. This allows a signal normalization up to 3 MHz.

The PDB48xC(-AC) is powered by an external linear power supply (± 12 V, 250 mA - included) via a PICO M8 power connector.

Below is a functional block diagram of the PDB48xC(-AC) Balanced Amplified Photodetectors:

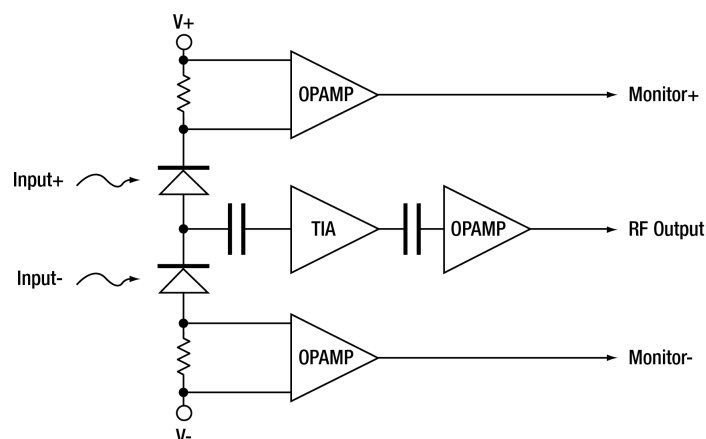

4.2 Optical Inputs

The PDB48xC(-AC) comes with fiber-coupled optical inputs. Both photo detectors are SMF28 (PDB480C-AC) resp. HI1060 (PDB481C-AC and PDB482C-AC) pigtailed and FC/APC connectorized. For this reason, a free space beam coupling directly to the PDB48xC(-AC) is not possible

The PDB48xC(-AC) can be used in balanced mode (both inputs are illuminated) as well as in single detector mode.

In order to avoid saturation, the output signal level should not exceed the RF output power 1-dB-compression point.

Attention

The damage threshold of the photo diodes is 10 mW (PDB480C-AC) resp. 5 mW (PDB481C-AC and PDB482C-AC)! Exceeding this value will permanently destroy the photo diode!

Note

Take care for clean fiber connectors prior to attach them to the PDB48xC(-AC)'s optical inputs! Clean and dust free connections are essential to minimize coupling loss and back reflections.

4.3 Electrical Outputs

The Thorlabs PDB48xC(-AC) has three SMA output connectors:

- **MONITOR +**
- **MONITOR -**
- **RF OUTPUT**

RF OUTPUT delivers an output voltage proportional to the difference between the photo currents of the two photodiodes This voltage can be calculated to:

$$U_{\text{RF,OUT}} = (P_{\text{opt},1} - P_{\text{opt},2}) \times \mathfrak{R}(\lambda) \times G$$

with: $\mathfrak{R}(\lambda)$ - responsivity of the photo diode at given wavelength
 $P_{\text{opt},1}$ and $P_{\text{opt},2}$ - optical input power
 G - transimpedance gain of the RF output

The responsivity $\mathfrak{R}(\lambda)$ for a given wavelength can be read from the individual curves in section Technical Data to estimate the **RF OUTPUT** voltage. Please note that the given responsivity curves represent typical values - individual responsivity may deviate.

The maximum **RF OUTPUT power** is typically + 18 dBm at 1 dB compression. To explain that: An ideal amplifier would be a linear device - its gain is constant at any input power level. In reality, the output power of the amplifier is limited (e.g. by supply voltage). That means, with increased input power the amplifier becomes saturated. Before saturation is reached, a reduction in gain takes place - the result is a compression effect. The 1 dB compression point is defined as the output power where the gain is 1 dB less than the small signal gain.

In order to avoid saturation, the output signal level should not exceed this 1-dB-compression point.

MONITOR Outputs

The signal monitor outputs (**MONITOR+** and **MONITOR-**) allow observation of the input power level and can be used as individual power indicators. These outputs can also be used to measure RF (up to 3 MHz) modulated signals on each detector separately. The maximum output voltage swing

of the **MONITOR** output is +10 V for high impedance loads (+1.5 V into 50 Ω). Saturation of **MONITOR** outputs will occur at optical input power level greater than 1 mW, depending on the detector's wavelength response.

The amplifier offset voltage is factory set to zero at 23°C ambient temperature. A small drift during a short warm-up period (~5min) may occur. For exact DC light level measurements a constant temperature environment is recommended.

4.4 Mounting

The PDB48xC(-AC) is housed in a rugged shielded aluminum enclosure.

For post mounting an adapter can be attached to the bottom or side surface using four M2x8 screws (see below). This adapter supports #8-32 as well as M4 post mounts. The M4 tread is marked.

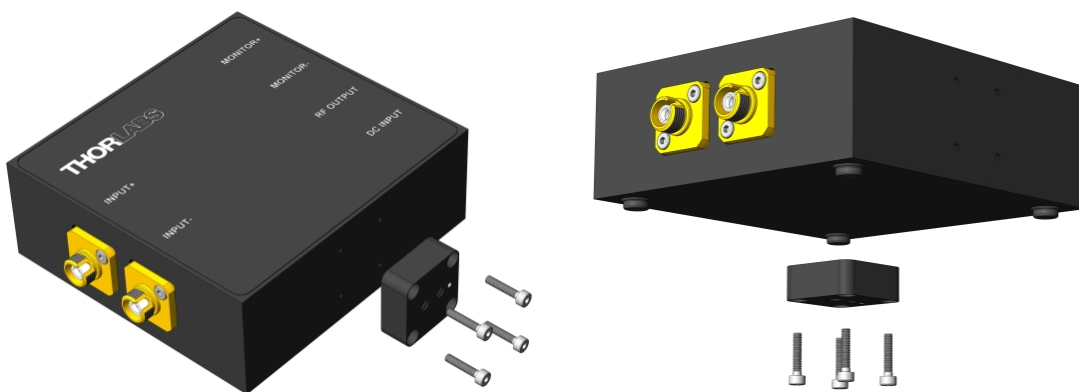

4.5 CMRR and Frequency Response

An important specification for balanced amplifiers is their ability to suppress common mode noise, which is reflected in the Common Mode Rejection Ratio (CMRR). In the setup as described below, the Device under Test (DuT) - here a PDB48xC(-AC) - is tested for CMRR. A common mode signal is generated, which is canceled out when the amplifier is in balanced mode.

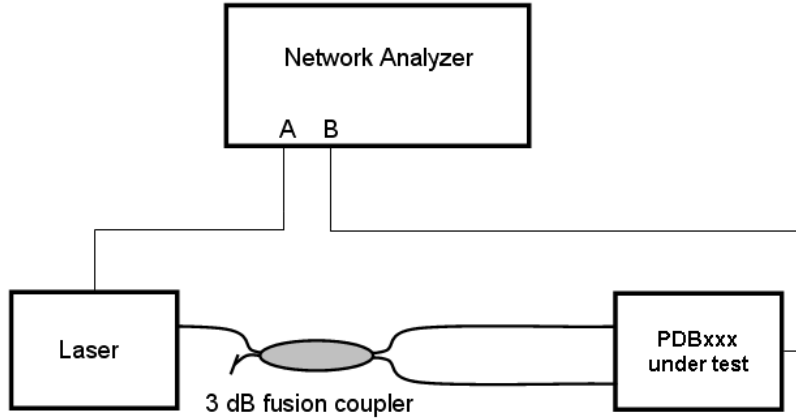

A network analyzer is used as signal generator (output A) and receiver (input B). The receiver is synchronized with the signal generator and measures selectively at the same frequency. A laser light source is modulated by the signal generator (port A) and acts as transmitter. To the laser output a 3 dB fusion coupler is connected, splitting the modulated light signal into two paths. Depending on the measurement task, one or both coupler outputs are connected to the inputs of the DuT. The output of the DuT that should be measured is connected to the network analyzer's Port B.

Frequency response measurements

The frequency response of each signal path can be measured by connecting only one coupler output to the appropriate input. This way, the frequency response curves of the RF OUTPUT from INPUT + and INPUT- can be measured, as well as the frequency responses of the MONITOR outputs, as shown in the individual technical data.

CMRR measurement

For Common Mode Rejection measurement, both outputs of the fusion coupler are connected to both inputs of the DuT. The optical power level at both inputs must be well matched ("balanced") in order to achieve the optimal common mode suppression. Now the common mode rejection can be measured as a function of frequency. The frequency response of the RF OUTPUT must be considered when calculating the CMRR - it is the difference between the RF OUTPUT signal at a given frequency and the measured common mode or balanced output signal - at the same frequency. Typical measurement curves can be found in the individual technical data.

4.6 Recommendations

Thorlabs PDB48xC(-AC) Balanced Amplified Photodetectors can eliminate noise sources to allow precise measurements. The PDB48xC(-AC) is designed to be used in a dual beam setup: one optical path for measurement and one invariant reference path. If set up properly, the PDB48xC(-AC) can reduce common mode noise for more than 25 dB over the specified frequency range. Below are given some recommendations to achieve an optimal common mode suppression:

- To obtain the maximum possible common mode rejection (common mode noise suppression), equal power levels on each photodetector are essential. Any power imbalance will be amplified and hence decrease the possible noise reduction.
- Equal optical path lengths are very important for common mode noise suppression especially at higher frequencies. Any path length difference will introduce a phase difference between the two signals, which will decrease the noise reduction capability of the balanced detector. The figure below shows the maximum allowed path length difference in fiber to obtain a desired CMRR.

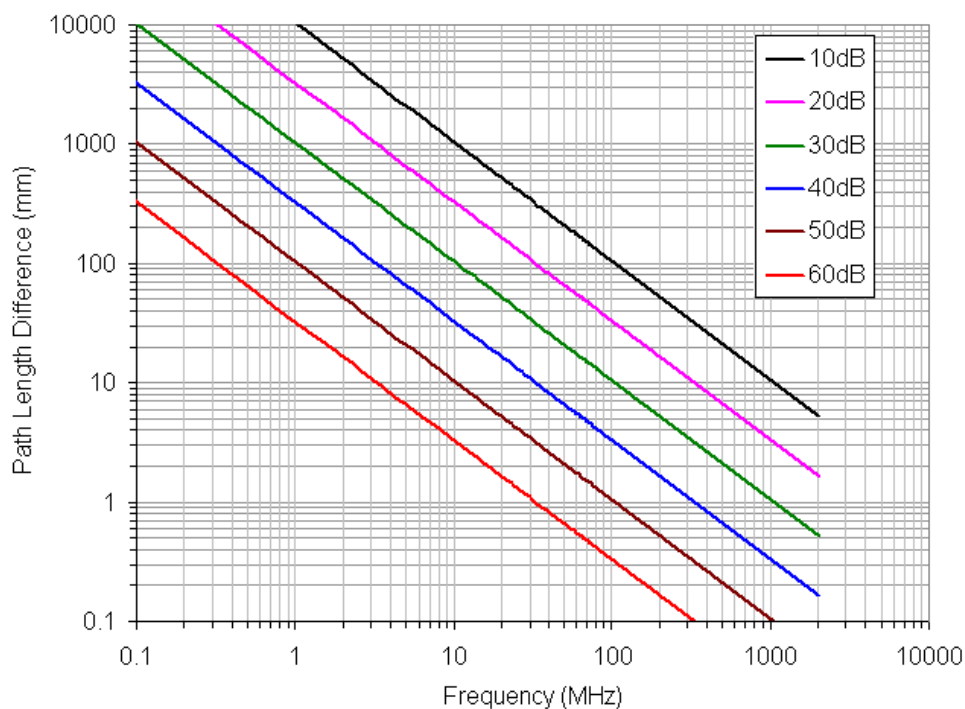

- Avoid etalon effects (interference fringes caused between two optical surfaces) in optical paths. Using angle polished optical connectors will greatly reduce etalon effects in a fiber based setup. Effects like residual frequency modulation, polarization noise, polarization wiggle or spatial modulation can also degrade common mode noise suppression. For further details contact Thorlabs. In general, reducing sources of differential losses in the optical paths (other than the measurement itself) will improve the common mode noise reduction.
- Another critical point can be electrostatic coupling of electrical noise associated with ground loops. In most cases an electrically isolated post (see Thorlabs parts TRE or TRE/M) will suppress electrical noise coupling. Always try to identify the electrical noise sources and increase the distance to the PDB48xC(-AC) Balanced Detector. Different common ground points can also be tested.

5 Maintenance and Service

Protect the PDB48xC(-AC) from adverse weather conditions. The PDB48xC(-AC) is not water resistant.

Attention

To avoid damage to the instrument, do not expose it to spray, liquids or solvents!

The unit does not need a regular maintenance by the user. It does not contain any modules and/or components that could be repaired by the user himself. If a malfunction occurs, please contact [Thorlabs](#) for return instructions.

Do not remove covers!

To clean the PDB48xC(-AC) series housing, use a mild detergent and damp cloth. Do not soak the unit in water or use solvent based cleaners.

Cleaning of the fiber connectors



The photodiodes of the PDB48xC(-AC) are pigtailed with single mode fiber and connectorized by FC/APC connectors. Clean and dust-free surfaces of the ferrule tips are essential to minimize coupling losses. If the connectors are suspected to be soiled, the ferrule tips can be cleaned this way:

Remove the two screws (1), fixing the front part (2) of the switchable adapter. Detach the front part (2) and clean the ferrule tip using a lint-free tissue damped with alcohol or propanol. The ferrule receptacle of the front part (2) can be cleaned from dust using compressed air (duster).

When mounting the front adapter, take care for its correct orientation: The cylindrical key of the front part must match with its counterpart in the PDB48xC(-AC)'s housing.

Warning

The screws (3), fixing the base of the switchable adapter to the housing, **must not be removed!**

6 Appendix

Comments and explanations to the individual specifications

- **Typical responsivity** $\mathfrak{R}(\lambda)$ of the photo diode at the stated wavelength.
- **Transimpedance [V/A]** is the ratio of output voltage to photo current, it is wavelength independent.
- **Conversion gain [V/W]** is the ratio of output voltage to input optical power, by other words

$$G_{CONV} = G_{TRANS} \times \mathfrak{R}(\lambda)$$

This formula shows, that the conversion gain is dependent on the actual wavelength. In specifications, it is given only for the indicated operating wavelength.

- **NEP** (Noise Equivalent Power) is stated for 30 kHz to 100 MHz frequency range.
- **Overall output voltage noise** $[V_{RMS}]$ is the value which can be measured across a 50 Ω load at large bandwidth, e.g., if connect the RF output to a 50 Ω terminated scope input.
- **Max. input power** is the damage threshold of the photo diode.
- **Typical noise spectra** (diagrams): These spectra were measured using an electrical spectrum analyzer (resolution bandwidth 100 kHz, video bandwidth 10 kHz). The INPUTs of the balanced detectors under test were blocked. The lower curve in the diagram was measured with the same setup and the balanced detectors under test switched off, i.e., it represents the measurement system's noise floor.
- **Monitor outputs** are designed for use with high impedance loads (e.g., high-Z scope input etc.), but can also drive 50 Ω loads. Monitor outputs conversion gain is given for the indicated operating wavelength and high impedance load.
- **Typical frequency response curves** are measured using the setup described in section ["CMRR and Frequency Response"](#)

6.1 Technical Data

Item #	PDB480C-AC	PDB481C-AC	PDB482C-AC
Detector			
Detector Type	InGaAs / PIN		
Optical Inputs	FC/APC (SMF28e+ Inside)	FC/APC (HI1060 Inside)	
Coupling Loss	< 0.5 dB (typ. < 0.3 dB)	<1.0 dB (typ. < 0.4 dB)	
Operating Wavelength	1300 nm (1200 - 1700 nm)	1060 nm (900 - 1400 nm)	
Responsivity, typ.	0.9 A/W @ 1550 nm	0.72 A/W @ 1060 nm	
Active Detector Diameter	0.075 mm	0.080 mm	
Optical Back Reflection	< -40 dB		
Photo Diode Damage Threshold	10 mW	5 mW	
RF OUTPUT			
RF OUTPUT Bandwidth (3 dB)	30 kHz to 1.6 GHz	30 kHz to 1.0 GHz	1 MHz to 2.5 GHz
Common Mode Rejection Ratio	>25 dB (typ. >30 dB)		>20 dB (typ. >25 dB)
RF OUTPUT Transimpedance Gain ^a	16 x 10 ³ V/A		28 x 10 ³ V/A
RF OUTPUT Conversion Gain ^a	14.4 x 10 ³ V/W @ 1550 nm	11.5 x 10 ³ V/W @ 1060 nm	20 x 10 ³ V/W @ 1060 nm
RF OUTPUT Power at 1 dB Compression ^a	Min. +16.5 dBm Typ. +18 dBm		
RF OUTPUT Coupling	AC Coupling Only		
RF Output Impedance	50 Ω		
Minimum NEP (@1060 nm) ^b	9.3 pW/√Hz	9.0 pW/√Hz	12.0 pW/√Hz
Overall Output Voltage Noise	< 9 mV _{RMS}	< 6.5 mV _{RMS}	< 12 mV _{RMS}
MONITOR Outputs			
MONITOR Output Impedance	200 Ω		
MONITOR Output Bandwidth (3 dB)	DC to 3 MHz		DC to 2.5 MHz
MONITOR Output Conversion Gain, High Z load	9 V/mW @ 1550 nm	7.2 V/mW @ 1060 nm	
MONITOR Output Voltage Swing High Z load	max. 10 V		
Overall Output Voltage Noise	< 0.65 mV _{RMS}		
DC Offset	< ± 2 mV		
General			
Electrical Outputs	SMA		
DC Power Supply	± 12V @ 250mA		
Operating Temperature Range	0 to 40 °C		
Storage Temperature Range	-40 to 70 °C		
Dimensions (W x H x D)	3.35" x 3.15" x 1.18" (85 mm x 80 mm x 30 mm)		
Weight	0.35 kg		

All technical data are valid at 23 ± 5°C and 45 ± 15% rel. humidity (non condensing)

a) @50 Ω load

b) 30 kHz to 100 MHz for PDB480C-AC and PDB481C-AC; 1 MHz to 100 MHz for PDB482C-AC

6.1.1 Individual Diagrams PDB480C-AC

PDB480C-AC: Typical Detector Responsivity

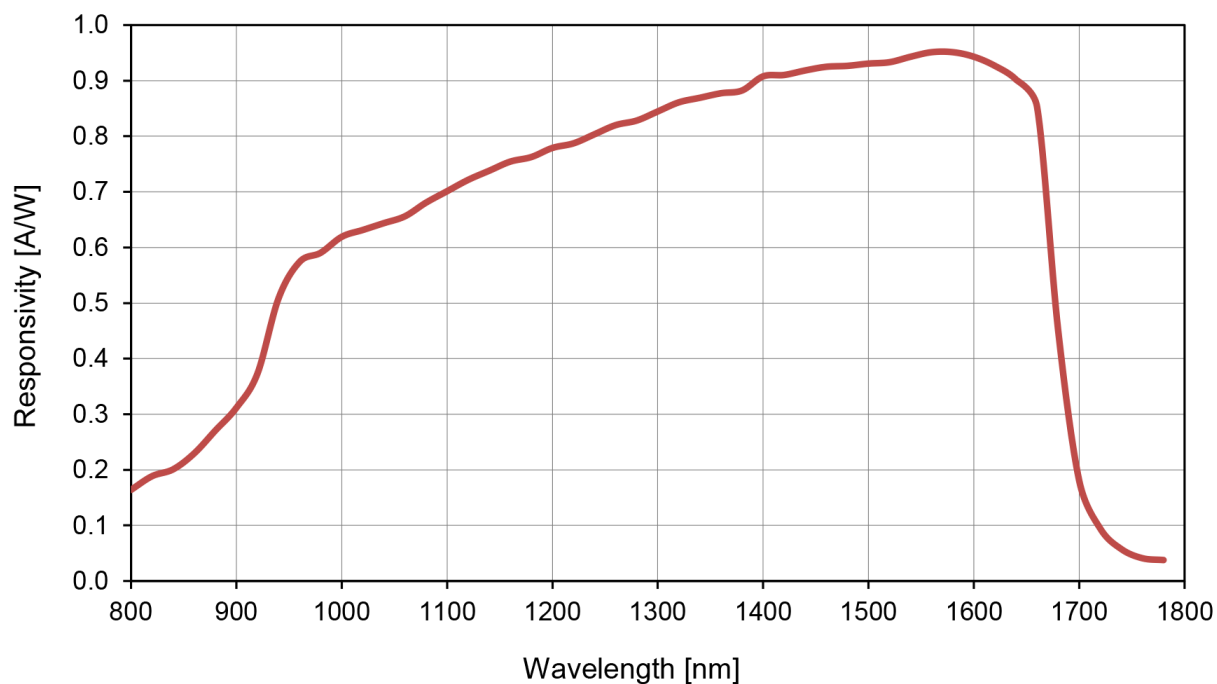

PDB480C-AC - Typical Detector Responsivity

PDB480C-AC: Typical RF OUTPUT Frequency Response

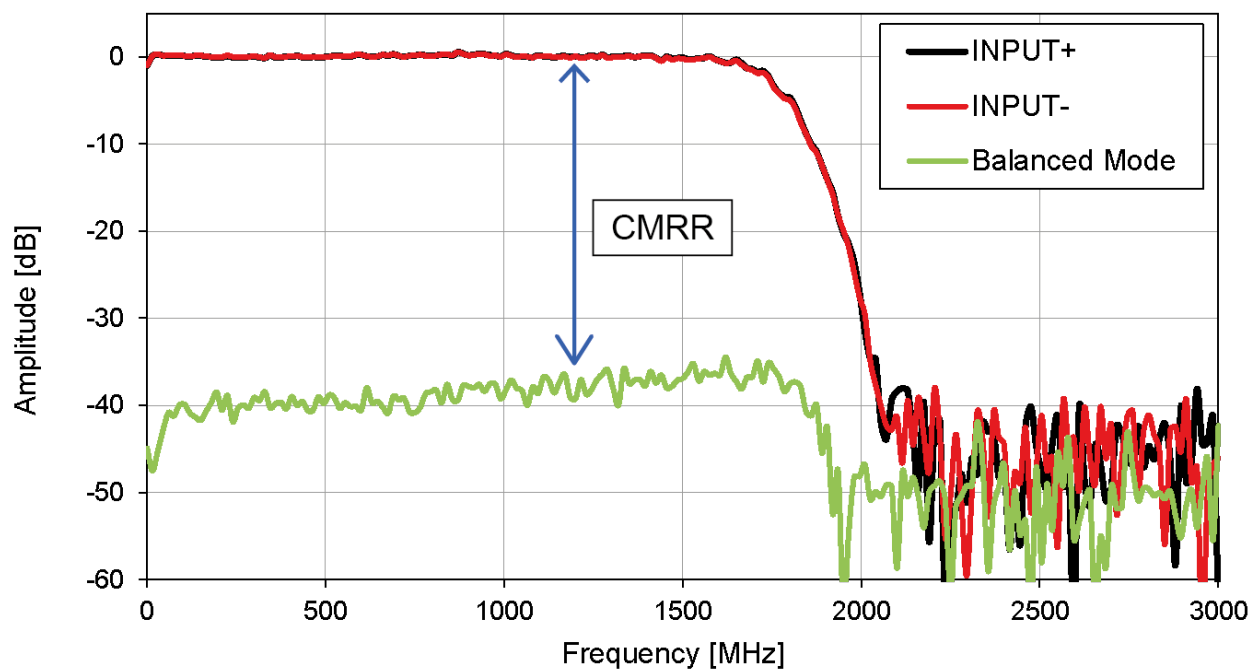

PDB480C-AC: Typical MONITOR OUTPUT Frequency Response

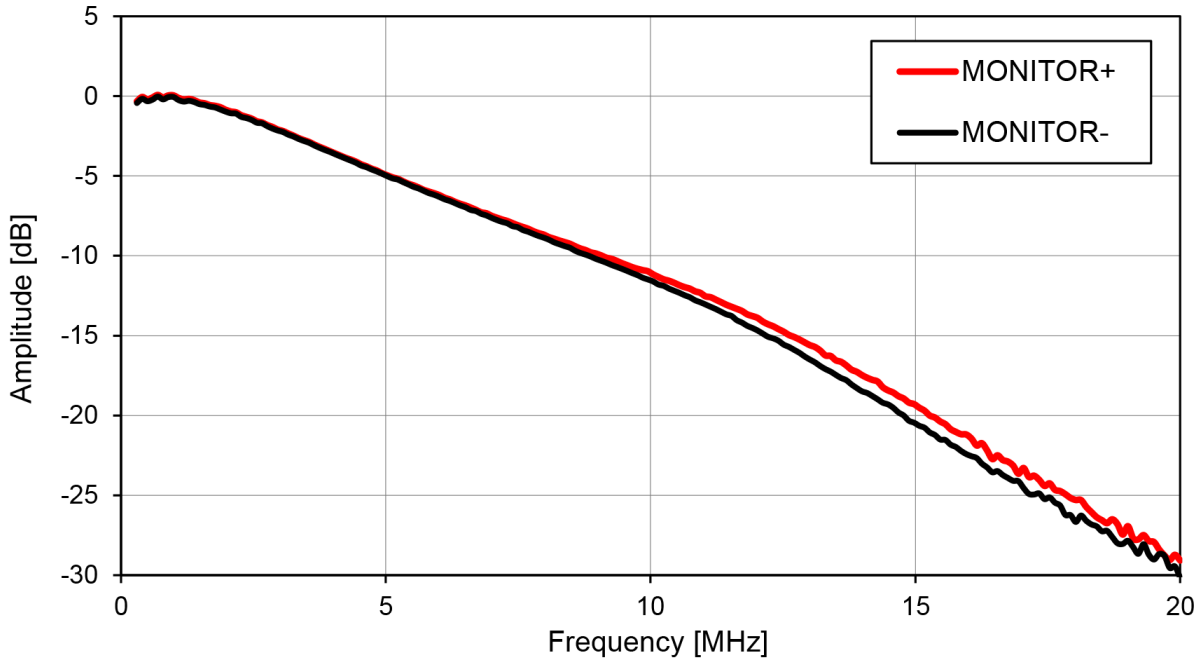

PDB480C-AC - Typical MONITOR Output Frequency Response

PDB480C-AC: Typical RF-OUTPUT Spectral Noise

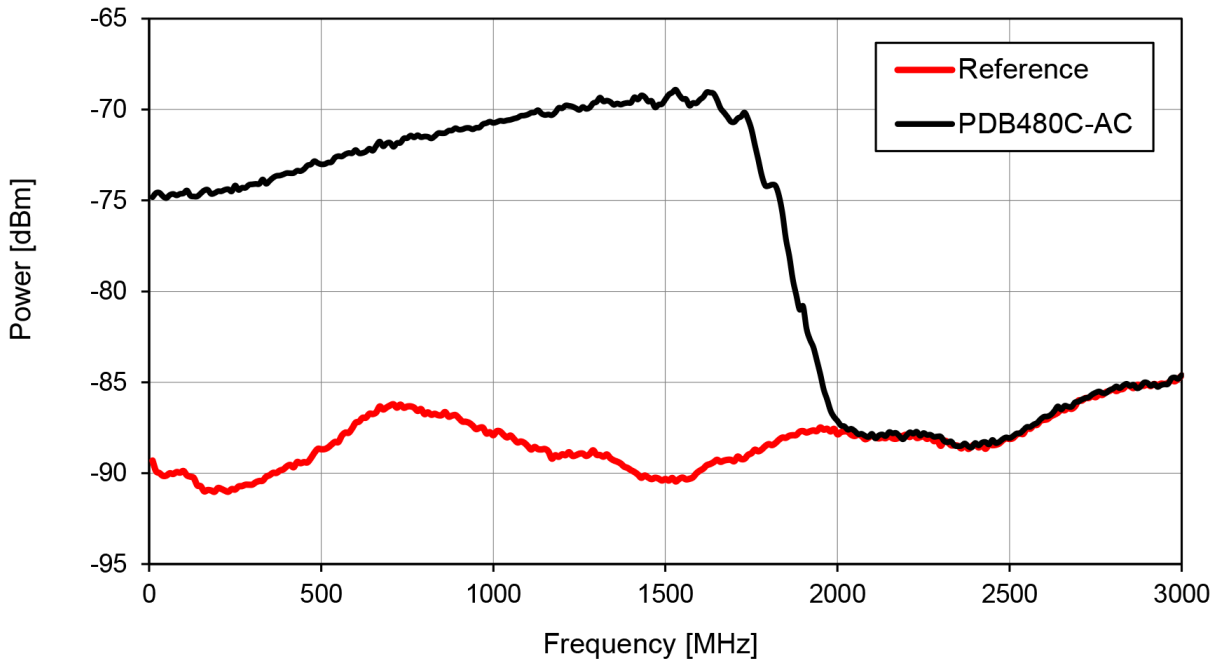

PDB480C-AC - Typical RF-OUTPUT Spectral Noise

6.1.2 Individual Diagrams PDB481C-AC

PDB481C-AC: Typical Detector Responsivity

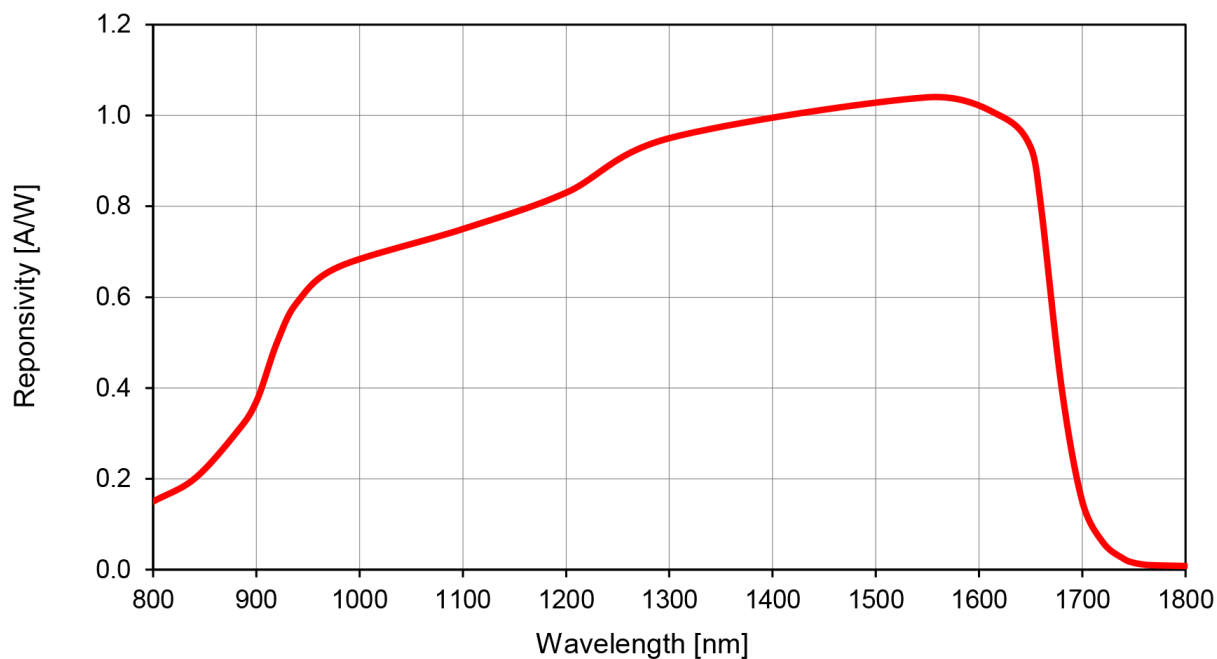

PDB481C-AC - Typical Detector Responsivity

PDB481C-AC: Typical RF OUTPUT Frequency Response

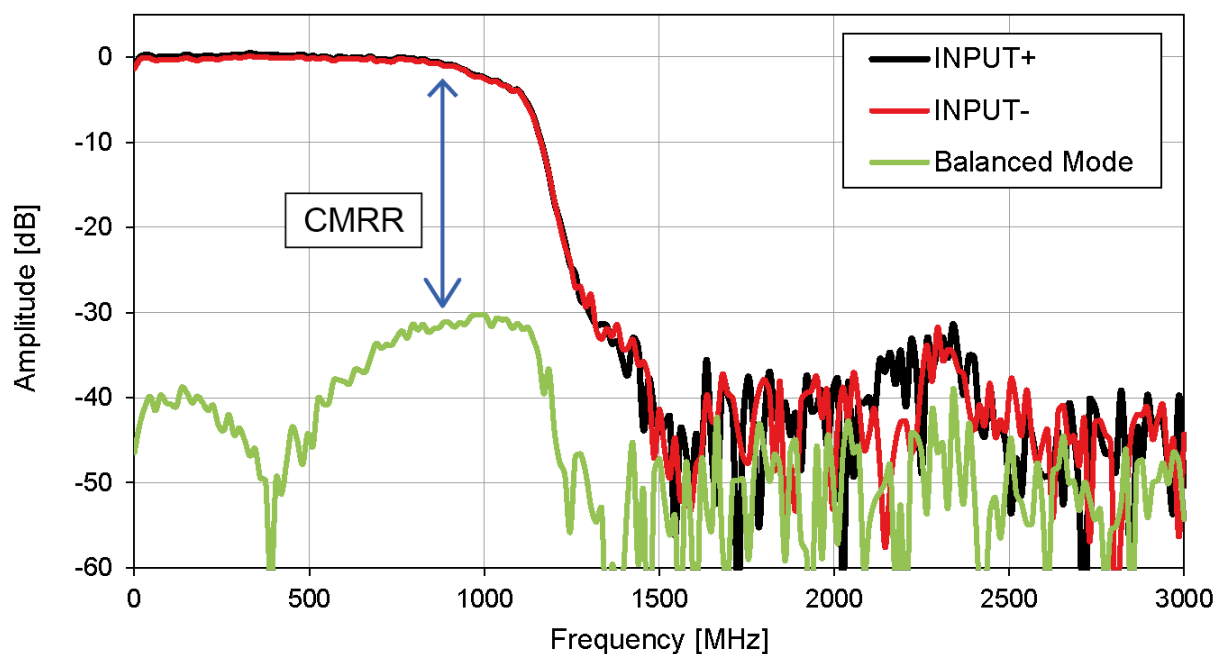

PDB481C-AC - Typical RF OUTPUT Frequency Response

PDB481C-AC: Typical MONITOR OUTPUT Frequency Response

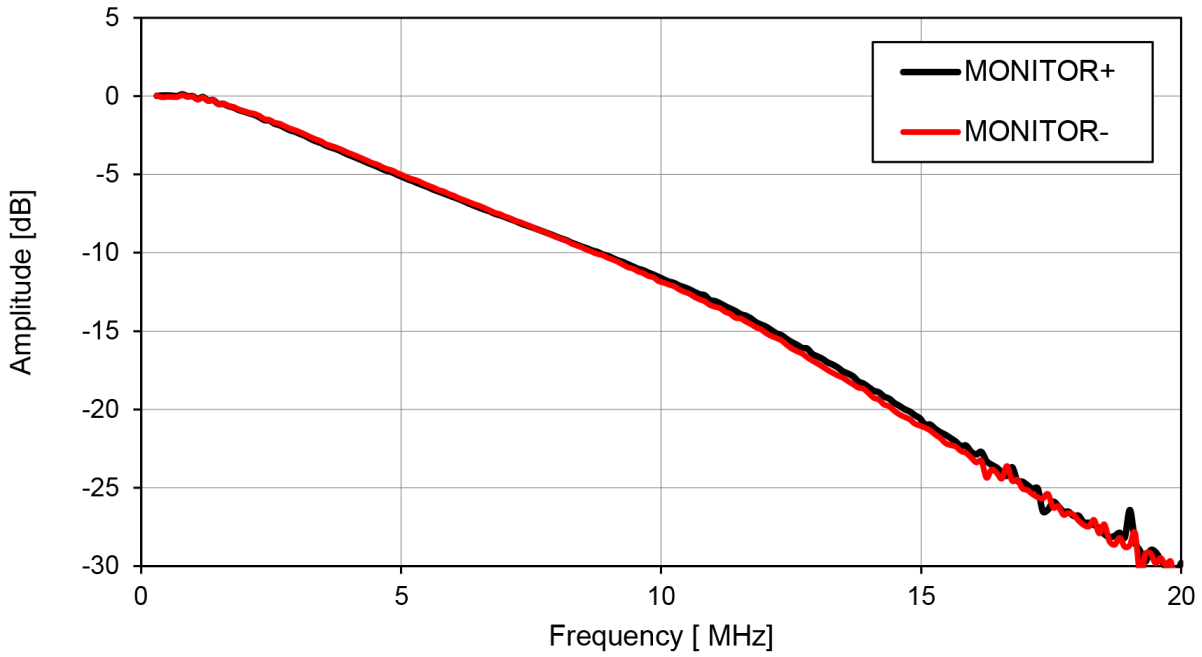

PDB481C-AC - Typical MONITOR OUTPUT Frequency Response

PDB481C-AC: Typical RF-OUTPUT Spectral Noise

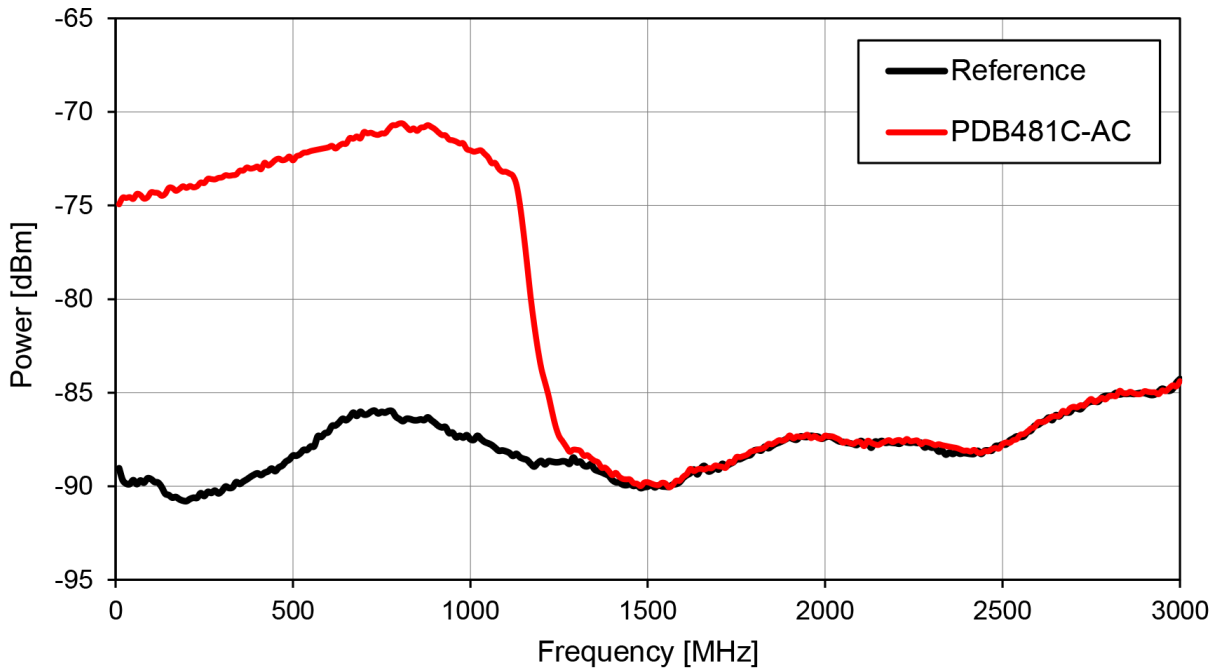

PDB481C-AC - Typical RF-OUTPUT Spectral Noise

6.1.3 Individual Diagrams PDB482C-AC

PDB482C-AC: Typical Detector Responsivity

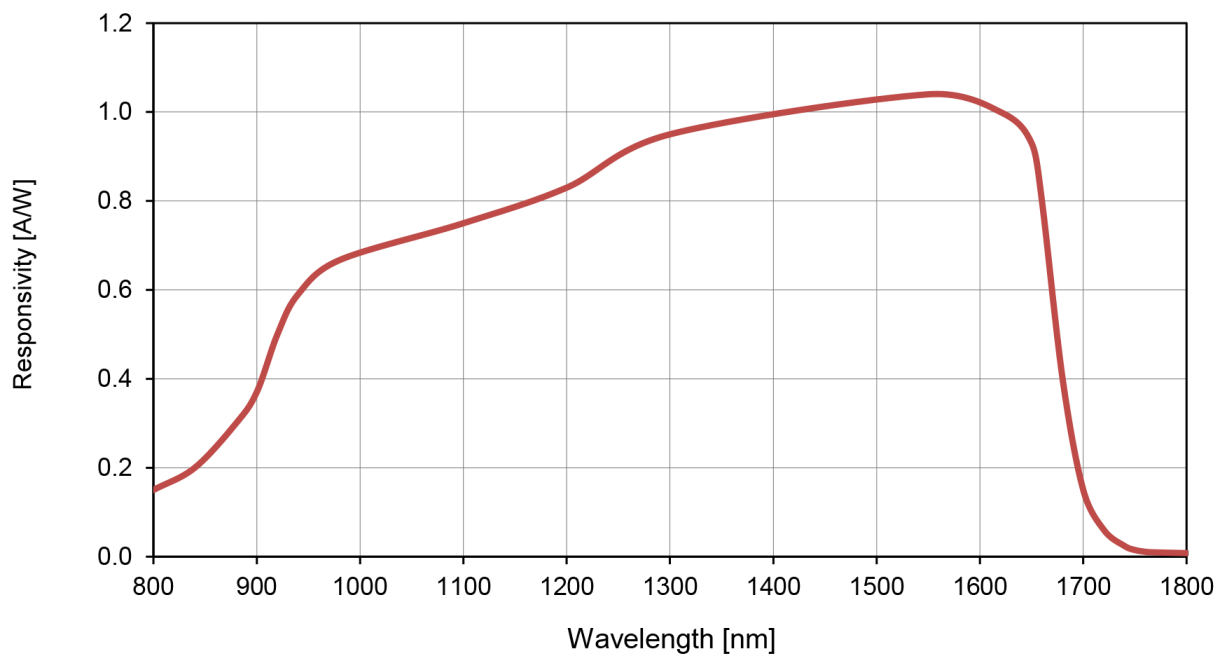

PDB482C-AC - Typical Detector Responsivity

PDB482C-AC: Typical RF OUTPUT Frequency Response

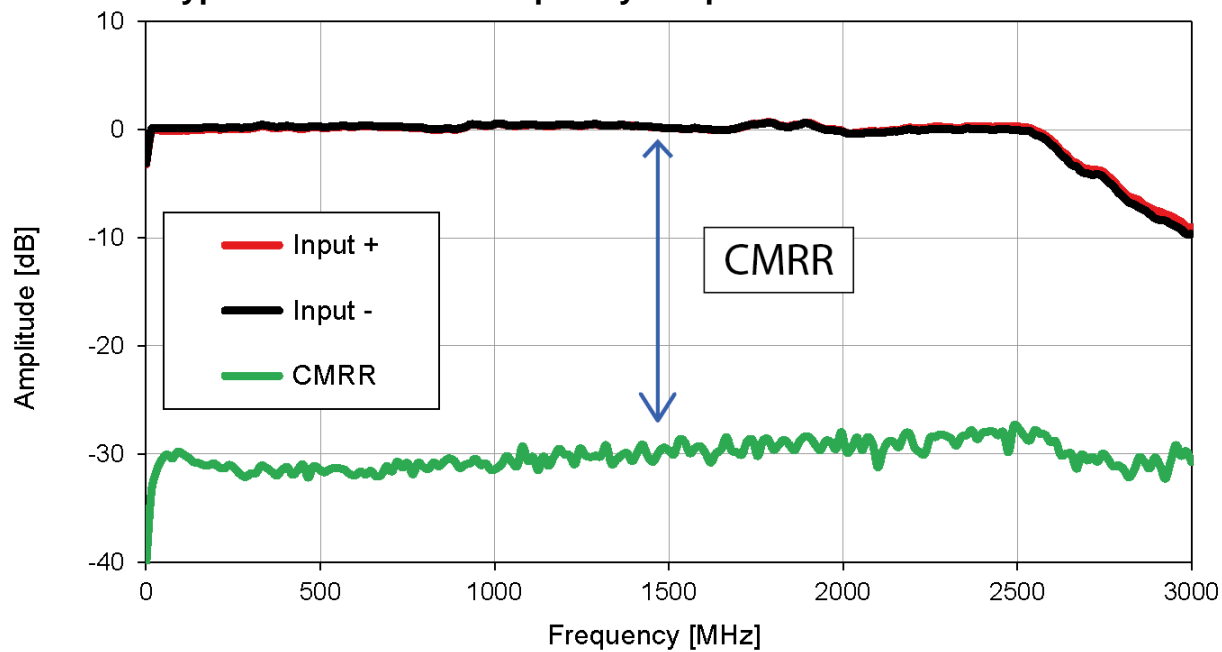

PDB482C-AC - Typical RF OUTPUT Frequency Response

PDB482C-AC: Typical MONITOR OUTPUT Frequency Response

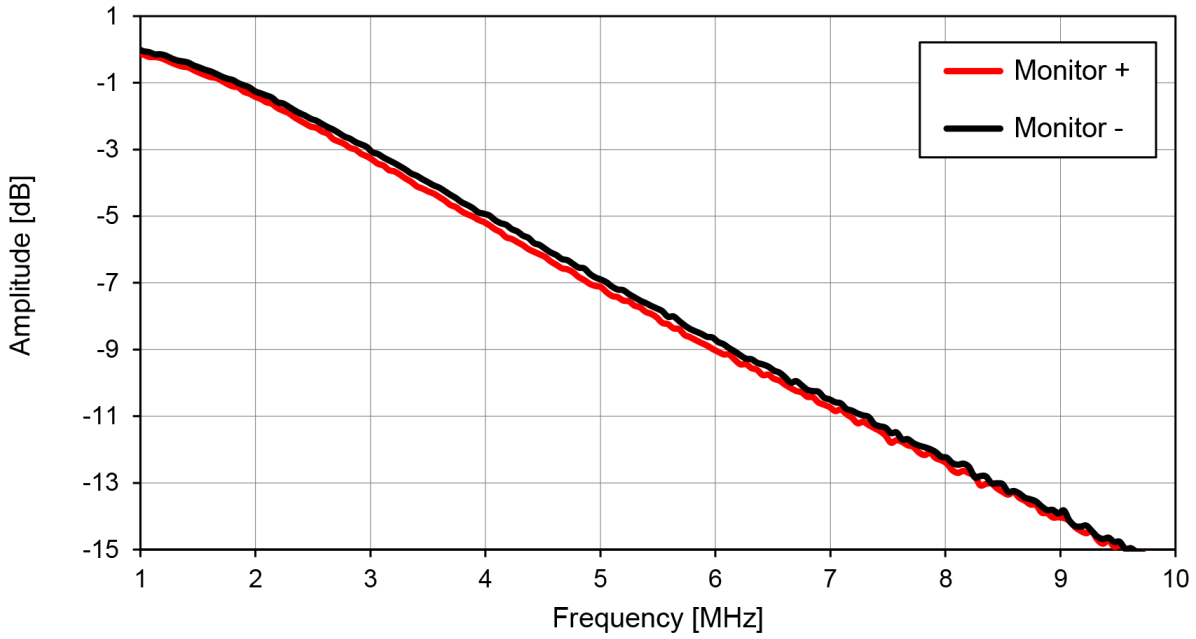

PDB482C-AC - Typical MONITOR Output Frequency Response

PDB482C-AC: Typical RF-OUTPUT Spectral Noise

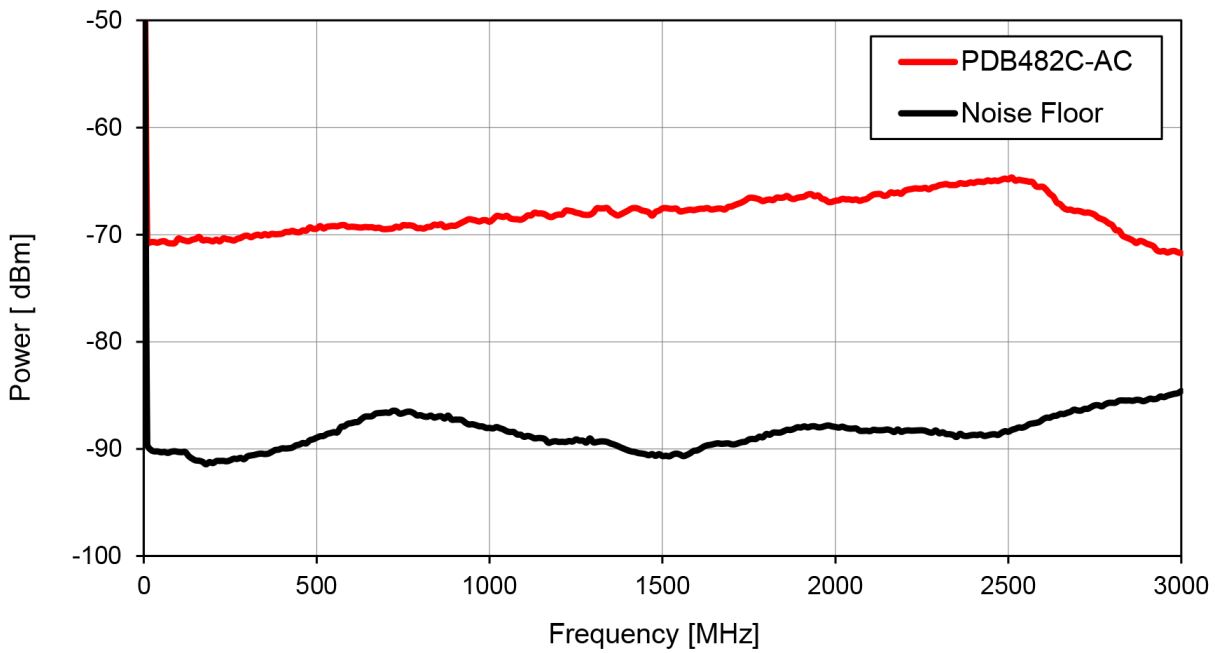

PDB482C-AC - Typical RF-OUTPUT Spectral Noise

6.2 Dimensions

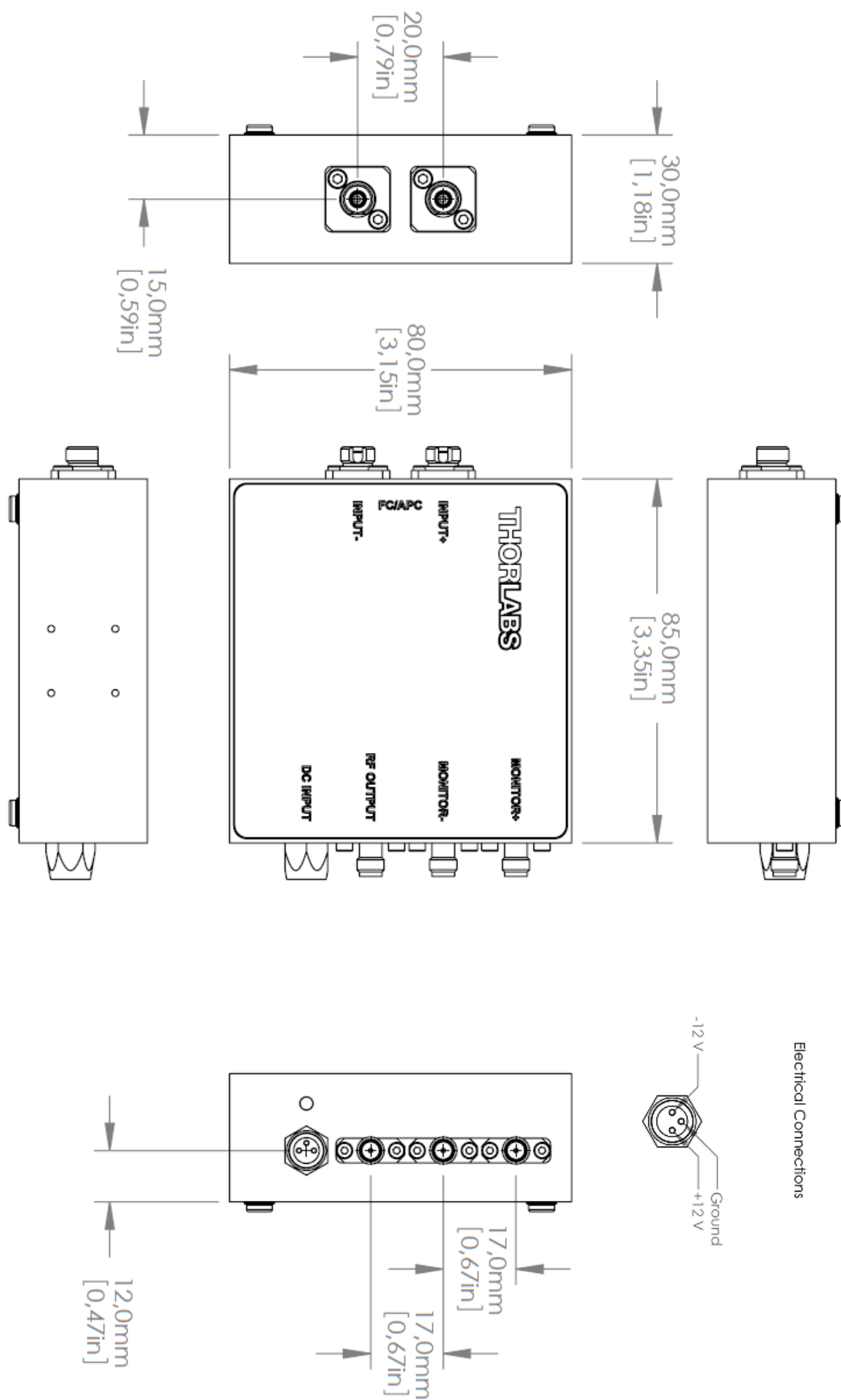

PDB48x(-AC) Mechanical Drawing

6.3 Safety

Attention

The safety of any system incorporating the equipment is the responsibility of the assembler of the system.

All statements regarding safety of operation and technical data in this instruction manual will only apply when the unit is operated correctly as it was designed for.



Do not remove covers! Do not open the cabinet. There are no parts serviceable by the operator inside!

This precision device is only serviceable if properly packed into the complete original packaging including the plastic foam sleeves. If necessary, ask for replacement packaging.

Refer servicing to qualified personnel!

Only with written consent from Thorlabs may changes to single components be made or components not supplied by Thorlabs be used.

6.4 Certifications and Compliances

<i>EU Declaration of Conformity</i>		
<i>in accordance with EN ISO 17050-1:2010</i>		
We:	Thorlabs GmbH	
Of:	Münchner Weg 1, 85232 Bergkirchen, Deutschland	
<i>in accordance with the following Directive(s):</i>		
2014/35/EU	Low Voltage Directive (LVD)	
2014/30/EU	Electromagnetic Compatibility (EMC) Directive	
2011/65/EU	Restriction of Use of Certain Hazardous Substances (RoHS)	
 <i>hereby declare that:</i>		
Model:	<i>PDB2*, PDB4*, PDB5*, PDB8*</i>	
Equipment:	<i>Fixed and switchable gain balanced amplifiers</i>	
 <i>is/are in conformity with the applicable requirements of the following documents:</i>		
EN 61010-1	Safety Requirements for Electrical Equipment for Measurement, Control and Laboratory Use.	2010 + A1:2019 + AC:2019.
EN 61326-1	Electrical Equipment for Measurement, Control and Laboratory Use - EMC Requirements	2013
 <i>and which, issued under the sole responsibility of Thorlabs, is/are in conformity with Directive 2011/65/EU of the European Parliament and of the Council of 8th June 2011 on the restriction of the use of certain hazardous substances in electrical and electronic equipment, for the reason stated below:</i>		
<i>contains no substances in excess of the maximum concentration values tolerated by weight in homogenous materials as listed in Annex II of the Directive</i>		
 <i>I hereby declare that the equipment named has been designed to comply with the relevant sections of the above referenced specifications, and complies with all applicable Essential Requirements of the Directives.</i>		
Signed:		On: 29 November 2022
Name:	Dr. Bruno Gross	
Position:	General Manager	EDC - PDB2*, PDB4*, PDB5*, PDB8*
		

6.5 Warranty

Thorlabs warrants material and production of the PDB48xC(-AC) for a period of 24 months starting with the date of shipment in accordance with and subject to the terms and conditions set forth in Thorlabs' General Terms and Conditions of Sale which can be found at:

General Terms and Conditions:

https://www.thorlabs.com/Images/PDF/LG-PO-001_Thorlabs_terms_and_%20agreements.pdf

and

https://www.thorlabs.com/images/PDF/Terms%20and%20Conditions%20of%20Sales_Thorlabs-GmbH_English.pdf

6.6 Return of Devices

This precision device is only serviceable if returned and properly packed into the complete original packaging including the complete shipment plus the cardboard insert that holds the enclosed devices. If necessary, ask for replacement packaging. Refer servicing to qualified personnel.

6.7 Manufacturer Address

Manufacturer Address Europe

Thorlabs GmbH
Münchner Weg 1
D-85232 Bergkirchen
Germany
Tel: +49-8131-5956-0
Fax: +49-8131-5956-99
www.thorlabs.de
Email: europe@thorlabs.com

EU-Importer Address

Thorlabs GmbH
Münchner Weg 1
D-85232 Bergkirchen
Germany
Tel: +49-8131-5956-0
Fax: +49-8131-5956-99
www.thorlabs.de
Email: europe@thorlabs.com

UK-Importer Address

Thorlabs, LTD.
204 Lancaster Way Business Park
Ely, CB6 3NX
UK
Tel: +44-1353-654440
Fax: +44 (0)1353-654444
www.thorlabs.com
Email: techsupport.uk@thorlabs.com

6.8 Copyright and Exclusion of Liability

Thorlabs has taken every possible care in preparing this document. We however assume no liability for the content, completeness or quality of the information contained therein. The content of this document is regularly updated and adapted to reflect the current status of the product.

All rights reserved. This document may not be reproduced, transmitted or translated to another language, either as a whole or in parts, without the prior written permission of Thorlabs. Copyright © Thorlabs 2023. All rights reserved.

Please refer to the general terms and conditions linked under [Warranty](#)²².

6.9 Thorlabs Worldwide Contacts and WEEE Policy

For technical support or sales inquiries, please visit us at <https://www.thorlabs.com/locations.cfm> for our most up-to-date contact information.



USA, Canada, and South America

Thorlabs, Inc.
sales@thorlabs.com
techsupport@thorlabs.com

UK and Ireland

Thorlabs Ltd.
sales.uk@thorlabs.com
techsupport.uk@thorlabs.com

Europe

Thorlabs GmbH
europe@thorlabs.com

Scandinavia

Thorlabs Sweden AB
scandinavia@thorlabs.com

France

Thorlabs SAS
sales.fr@thorlabs.com

Brazil

Thorlabs Vendas de Fotônicos Ltda.
brasil@thorlabs.com

Japan

Thorlabs Japan, Inc.
sales@thorlabs.jp

China

Thorlabs China
chinasales@thorlabs.com

Thorlabs 'End of Life' Policy (WEEE)

Thorlabs verifies our compliance with the WEEE (Waste Electrical and Electronic Equipment) directive of the European Community and the corresponding national laws. Accordingly, all end users in the EC may return "end of life" Annex I category electrical and electronic equipment sold after August 13, 2005 to Thorlabs, without incurring disposal charges. Eligible units are marked with the crossed out "wheelie bin" logo (see right), were sold to and are currently owned by a company or institute within the EC, and are not disassembled or contaminated. Contact Thorlabs for more information. Waste treatment is your own responsibility. "End of life" units must be returned to Thorlabs or handed to a company specializing in waste recovery. Do not dispose of the unit in a litter bin or at a public waste disposal site. It is the users responsibility to delete all private data stored on the device prior to disposal.

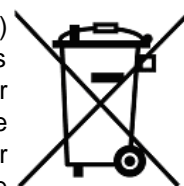



THORLABS
www.thorlabs.com
