

M450D4

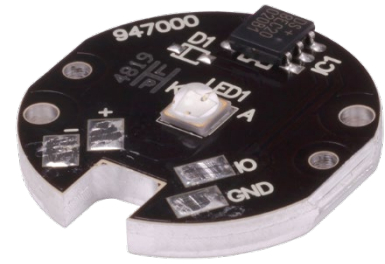

Description

This Thorlabs LED on a Metal-Core Printed Circuit Board (MCPCB) is designed to provide high-power output in a compact package. For specifications, please see the table below.

Thermal Management

Please note that operation of this LED requires mounting of the LED to an adequate heat sink. For proper thermal management, fix the MCPCB to a heat sink using two screws and use a thermal compound to provide good thermal contact between the MCPCB and the heat sink.

Specifications

Specification	Value
Color	Royal Blue
Nominal Wavelength	450 nm
Bandwidth (FWHM) ^a	18 nm
Viewing Angle (Full Angle) ^{a,b}	120°
Emitter Size	1.5 mm x 1.5 mm
Maximum Current (CW) ^a	2000 mA
Electrical Power ^a	6400 mW
Typical Lifetime ^a	>10 000 h
Operating Temperature (Non-Condensing)	-40 to 120 °C
Storage Temperature	-40 to 120 °C
Risk Group ^c	RG2 - Moderate Risk Group

a. Measured at 25 °C

b. When Driven at the Current of 700 mA

c. According to the Standard IEC 62471:2006, Photobiological Safety of Lamps and Lamp Systems

	Symbol	Min	Typical	Max
Peak Wavelength ^{a,b}	λ_p	444 nm	450 nm	457 nm
LED Power Output ^{a,c}	P_{out}	2118.1 mW	3041.5 mW	-
Forward Voltage ^{a,c}	V_F	-	3.2 V	-
Maximum Irradiance ^{a,c,d}	E_e	-	34.2 $\mu\text{W}/\text{mm}^2$	-

a. Measured at 25 °C

b. When Driven at the Current of 700 mA

c. When Driven with the Maximum Current

d. Measured at a Distance of 200 mm

Typical Performance Plots

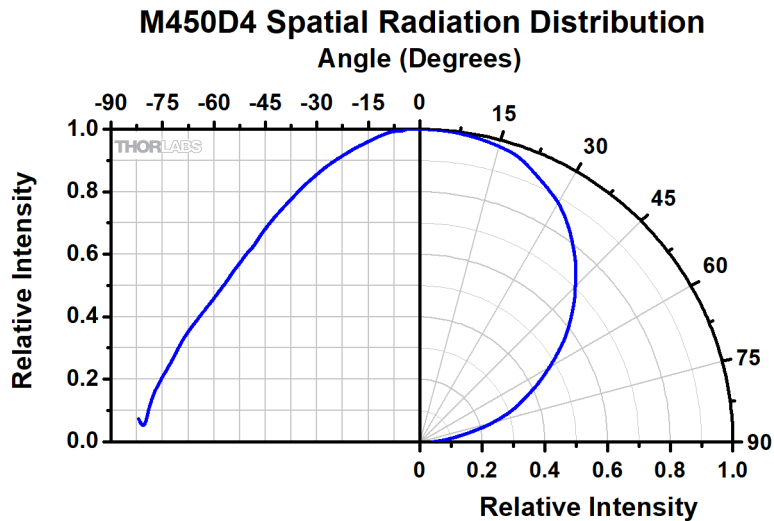
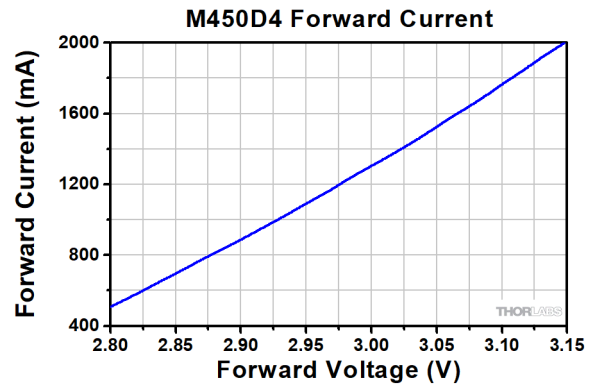
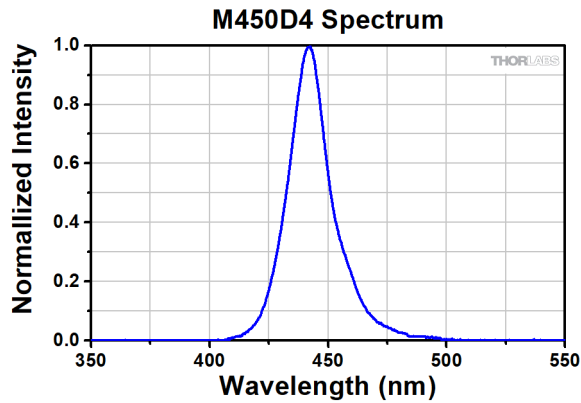

Forward Current and Spatial Radiation Distribution Data Refer to the Bare LED. Spectrum Data was Measured at 25 °C with a 2000 mA Driving Current.

Drawings

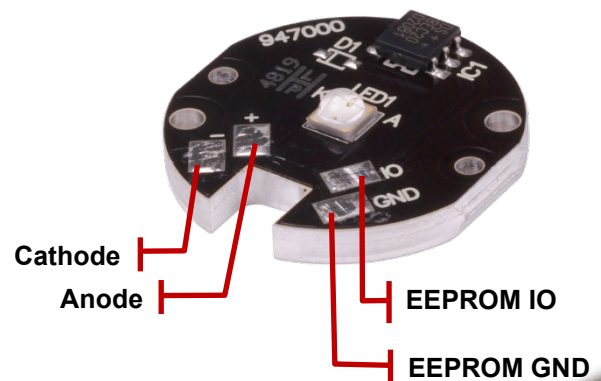
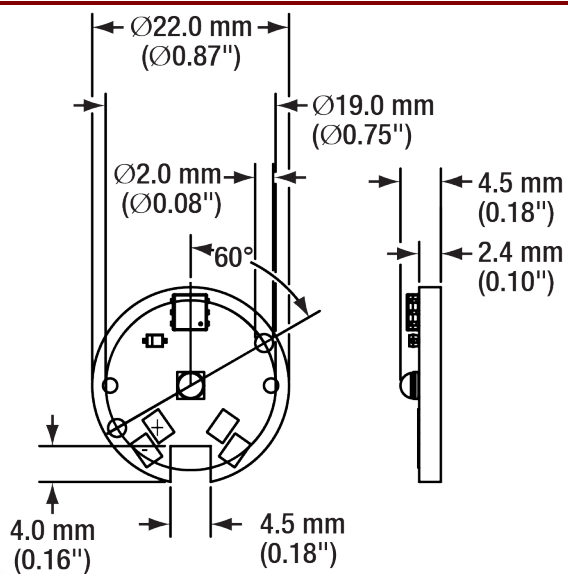

Power Supply

Please see the Thorlabs website for the available LED drivers. When selecting the LED driver, ensure that:

- The operating current never exceeds the maximum current specified in the LED specification table.
- Sufficient forward voltage is supplied.

If you decide to use your own DC source, please ensure that the correct connection is made to Pins 1 and 2.

Maintenance and Service

This LED is not water resistant and must be protected from adverse weather conditions. To avoid damage, do not expose it to spray, liquids, or solvents. This LED does not contain any parts serviceable by the user and does not require regular user maintenance. Do not open the enclosure. If a malfunction occurs, contact Thorlabs for return instructions.

Warnings and Safety

During normal operations, the PCB temperature may exceed ambient temperature. To prevent higher PCB temperatures, the product should be operated without anything hindering air movement around the cooling system attached by the customer.

Please note that this product is not suitable for household room illumination.

This LED must not be operated in explosive environments and should only be used with shielded connection cables.

All statements regarding safety of operation and technical data only apply when the unit is operated correctly according to its specifications. The safety of any system incorporating the equipment is the responsibility of the assembler of the system.

Inappropriate use of any LED product may result in permanent eye damage. To prevent injury, use this product in accordance with the International Standard "Photobiological Safety of Lamps & Lamp Systems" IEC 62471. This product falls under Risk Group RG2 - Moderate Risk Group in accordance to the standard IEC 62471:2006.

If using this LED in a microscope application as a replacement for a mercury vapor lamp, the same precautions should be taken.

UV / Visible Radiation Warning Statement

This LED emits intense UV / visible radiation during operation. Do not look directly into the UV / visible light or look through the optical system during operation, as this can be harmful to the eyes, even for brief periods of exposure, due to the high intensity of the light. If viewing the UV / visible light directly is necessary, protective glasses must be worn to avoid eye damage.

WARNING	
	<p>UV LEDs UV emitted from this product. Avoid eye and skin exposure to unshielded products.</p>
	<p>VIS LEDs Possibly hazardous optical radiation is emitted from this product. Do not look at operating lamp. Eye injury may result.</p>

CAUTION!
<p>TO ENSURE PROPER HEAT MANAGEMENT, MOUNT THE METAL CORE PRINTED CIRCUIT BOARD (MCPCB) TO AN ADEQUATE HEAT SINK</p>

