

M365D2

Description

Thorlabs' M365D2 LED on a Metal-Core Printed Circuit Board (MCPCB) is designed to provide high-power output in a compact package and has a nominal wavelength of 365 nm. The minimum emitted power is 1150 mW, and the typical emitted power is 1400 mW. For more specifications, please see the table below.

Thermal Management

Please note that this LED must be operated when mounted to an adequate heat sink. For proper thermal management, fix the MCPCB to a heat sink using two screws, while using a thermal compound to provide good thermal contact between the MCPCB and the heat sink.

Specifications

Specifications	
Color	UV
Nominal Wavelength	365 nm
Bandwidth (FWHM)	9 nm
Viewing Angle (Full Angle)	120°
Maximum Current (CW)	1700 mA
Electrical Power (Max)	6800 mW
Typical Lifetime	>10 000 h
Chip Size	1.4 mm x 1.4 mm
MCPCB Thickness	2.4 mm
Operating Temperature (Non- Condensing)	0 to 40 °C
Storage Temperature	-40 to 70 °C
Risk Group ^a	RG2 - Moderate Risk Group

a. According to the Standard IEC 62471:2006, Photobiological Safety of Lamps and Lamp Systems

M365D2				
	Symbol	Min	Typical	Max
Peak Wavelength ^a	λ_p	360 nm	365 nm	370 nm
LED Output Power ^a	P_{out}	1150 mW	1400 mW	-
Forward Voltage	V_F	-	4.0 V	-
Maximum Irradiance ^{a,b}	E_e	-	17.6 $\mu\text{W}/\text{mm}^2$	-

a. When Driven with a Current of 1000 mA

b. Measured at a Distance of 200 mm

Performance Plots

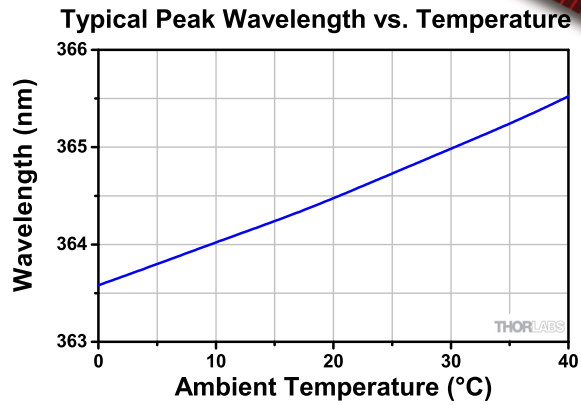
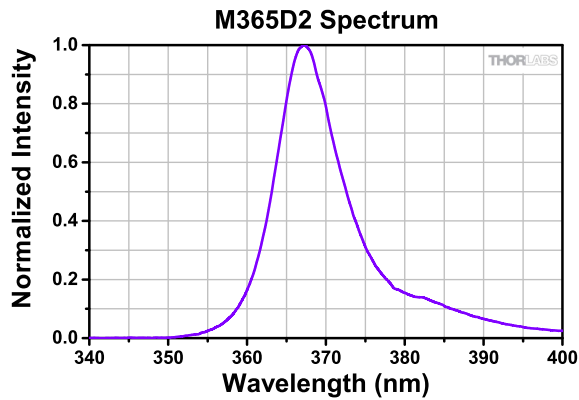

For the bare LED.

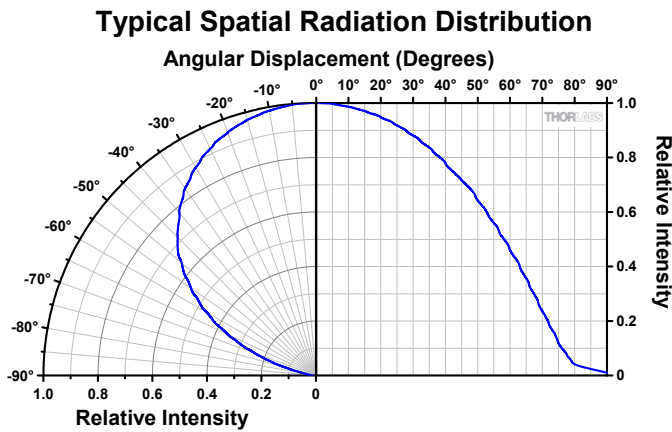

For the bare LED.

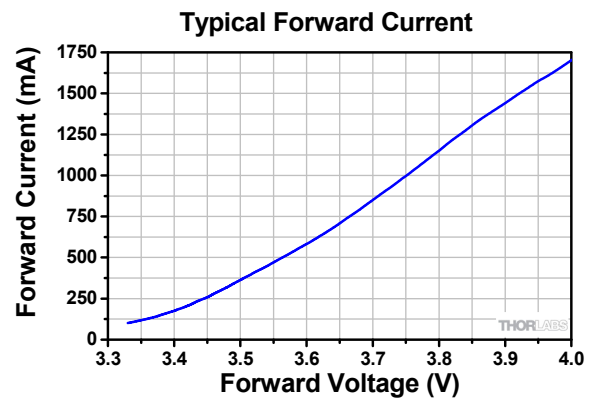

Drawing and Electrical Connections

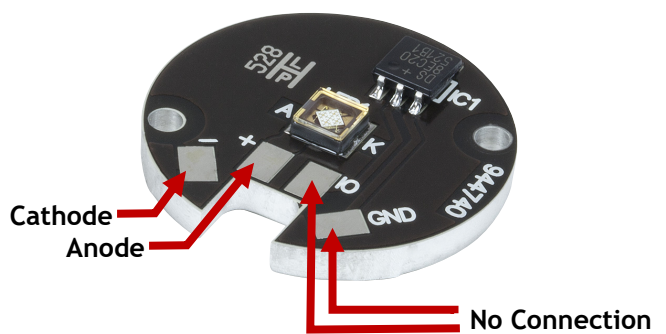
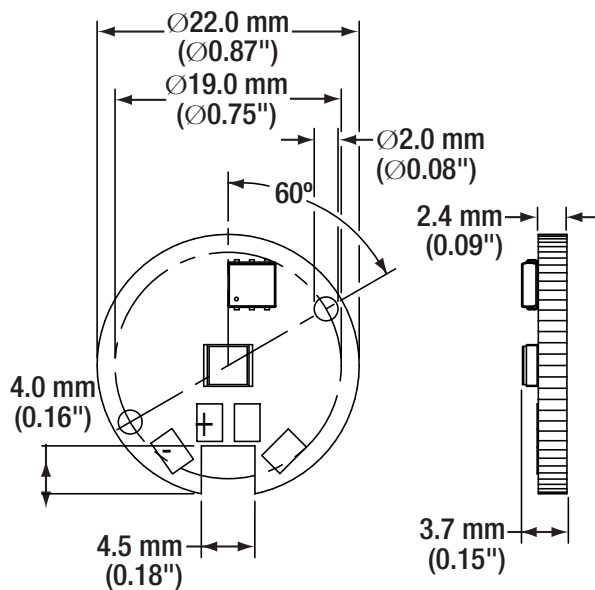

Power Supply

We recommend using Thorlabs' DC2200 or LEDD1B LED current drivers (for control of a single LED). Alternatively, the DC4100 or DC4104 current driver can be used with the DC4100-HUB, which allows simultaneous control of up to 4 individual LEDs.

If you decide to use your own DC source, please make sure that the operating current does not exceed the maximum allowed value, sufficient forward voltage is supplied, and that the correct connection is made to Pins 1 and 2.

Maintenance and Service

This LED is not water resistant and must be protected from adverse weather conditions. To avoid damage, do not expose it to spray, liquids, or solvents. The LED does not contain any parts serviceable by the user and does not require regular user maintenance. If a malfunction occurs, contact Thorlabs for return instructions.

Warnings and Safety

Inappropriate use of any LED product may result in permanent eye damage. To prevent injury, use this product in accordance with the International Standard "Photobiological Safety of Lamps & Lamp Systems" IEC 62471. This product falls under Risk Group RG2 - Moderate Risk Group in accordance to the standard IEC 62471:2006.

If using this LED in a microscope application as a replacement for mercury vapor lamp, the same precautions should be taken.

Please note that this product is not suitable for household room illumination.

This LED must not be operated in explosive environments and should only be used with shielded connection cables.

All statements regarding safety of operation and technical data only apply when the unit is operated correctly according to its specifications. The safety of any system incorporating the equipment is the responsibility of the assembler of the system.

Warning Statement

This LED emits intense UV radiation during operation. Precautions must be taken to prevent looking directly at the UV light. If viewing the UV light is necessary, UV light protective glasses must be worn to avoid eye damage. Do not look directly into the UV light or look through the optical system during operation, as this can be harmful to the eyes, even for brief periods, due to the high intensity of the UV light.

