

DFB09XX000TC060MXXXX

Distributed Feedback (DFB) Laser in 9mm TO-can header

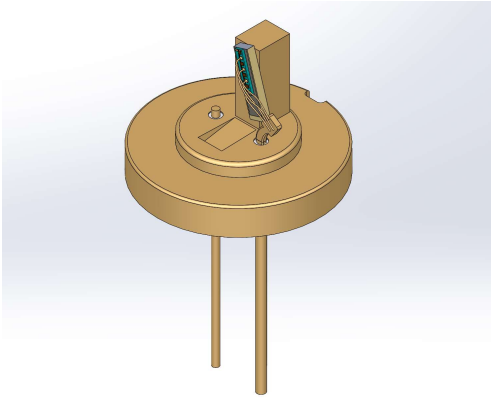

Features:

- Output power > 60mW ex-facet in 968-986nm range
- Proprietary mirror coating technology enabling high reliability
- Reliable Au/Sn bonding
- RoHS compliance
- Optional: cap
- Optional: mounting on open heatsink (C-mount or AIN carrier)

Applications:

- Fiber sensors
- Medical and biomedical devices

Recommended Operating Conditions

@ CW, sample is mounted on a copper heatsink

Parameter	Min.	Typ.	Max.	Unit
Heatsink Temperature	20	25*	40	°C
Forward Current		100	120	mA
Output Power**	5		60	mW

* in some cases may vary depending on the selected wavelength

** kink-free over the entire range

Characteristics

@ CW, heatsink temperature 25°C*, 100mA

Parameter	Min.	Typ.	Max.	Unit
Forward Current @ 60mW			120	mA
Forward Voltage @ 60mW		1.3	2	V
Threshold Current		20	40	mA
Peak Wavelength** (chosen by customer)	968		986	nm
Peak Wavelength Tolerance			±1	nm
Wavelength Temperature Tunability		90		pm/°C
Wavelength Current Tunability		1.5		pm/mA
Side-Mode Suppression Ratio (SMSR)	40	45		dB
Slow Axis Beam Divergence (FWHM)***	5	8	13	deg
Fast Axis Beam Divergence (FWHM)***	33	38	45	deg
Polarization Extinction Ratio (PER)	15	18		dB
Polarization		TE		

* in some cases may vary in 20-40°C range depending on the selected wavelength

** reachable within wavelength tolerance at power 60mW

*** FF specified for all chip batches in 968-986nm range; more precise data available on request for specific chip batch

Chip parameters

Parameter	Min.	Typ.	Max.	Unit
Chip length		2		mm
Back-reflection from Front Facet		0.001	0.01	%
Back-reflection from Back Facet		99		%

Typical Performance (for reference only)

@ CW, recommended operating conditions

Light-Current-Voltage Characteristics

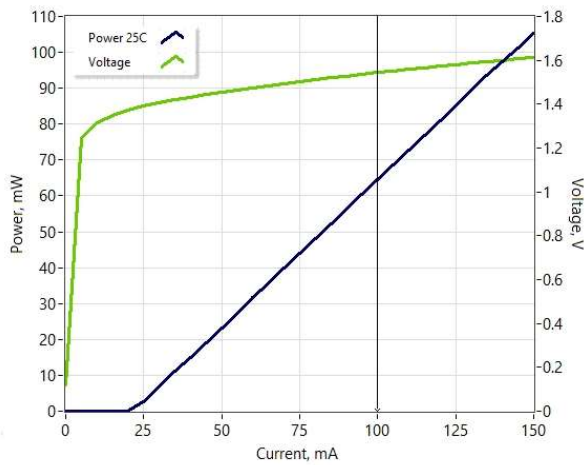

Optical Spectra (res. 10pm)

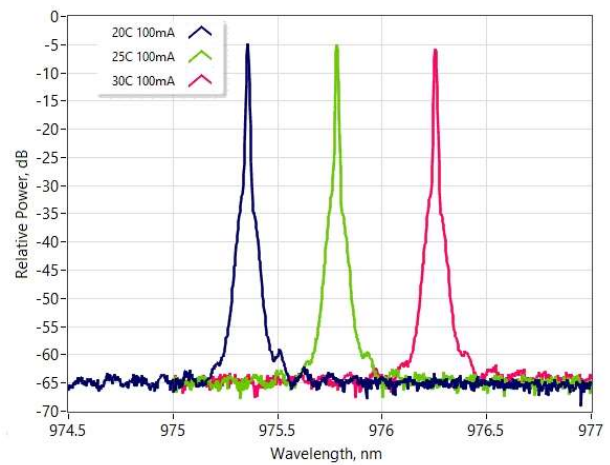

Slow Axis Far Field

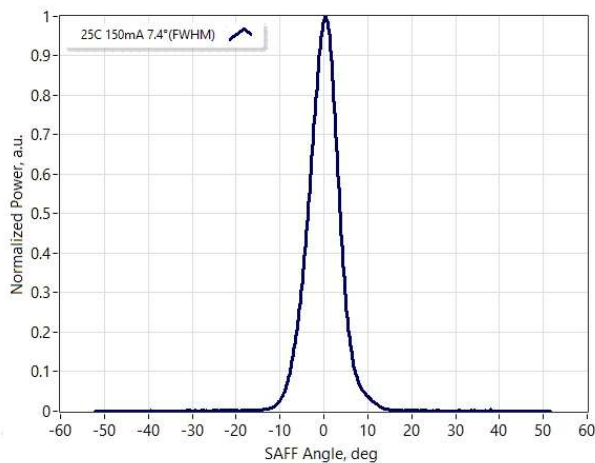

Fast Axis Far Field

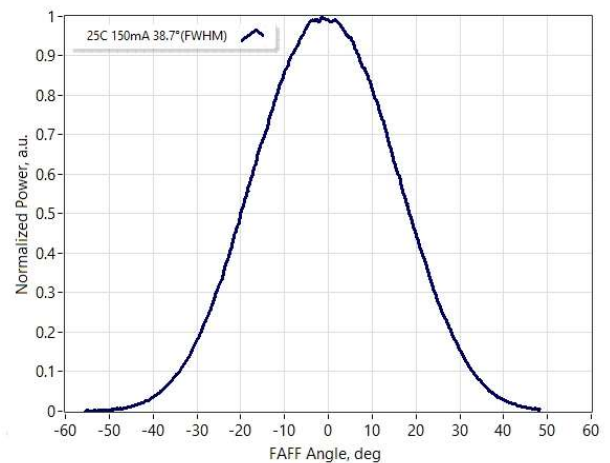

Absolute Maximum Ratings

Parameter	Min	Max	Unit
Forward Current		150	mA
Reverse Voltage		2	V
Operating temperature (above dew point)	10	50	°C
Storage Temperature (in original hermetically sealed package)	-40	85	°C
Lead Soldering Temperature (max 5 sec.)		250	°C

Dimensions (in mm)

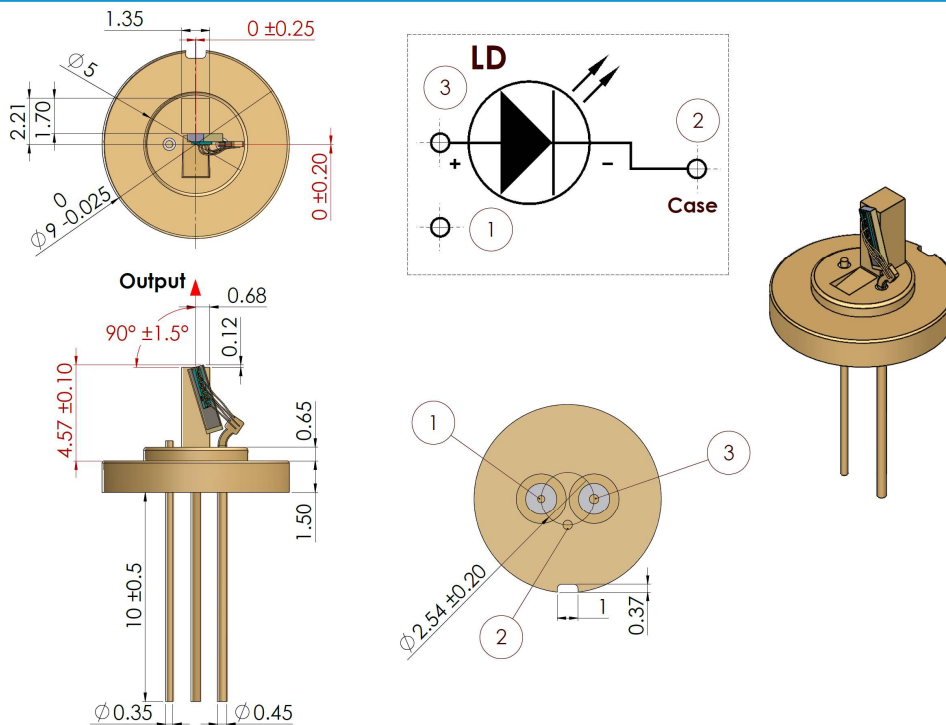

Note: Tolerances ± 0.15 (if not spec)

Safety and Operating Instructions

The laser light emitted from this Device is invisible and harmful to the human eye. Avoid looking directly into the fiber output or into the collimated beam along its optical axis when the device is in operation. Proper laser safety eyewear must be worn during operation.

Absolute Maximum Ratings may be applied to the Device for short period of time only. Exposure to maximum ratings for extended period of time or exposure above one or more maximum ratings may cause damage or affect the reliability of the Device.

Operating the Device outside of its maximum ratings may cause device failure or a safety hazard. Power supplies used with the Device must be employed such that the maximum forward current cannot be exceeded. A proper heatsink for the Device on thermal radiator is required, sufficient heat dissipation and thermal conductance to the heatsink must be ensured. It's recommended using of Indium metal foil (or similar) between TO-header and heatsink surface for thermal interface.

Avoid back reflection to the device. It may give impact on the device performance in aspects of spectrum and power stability. It also may cause fatal facet damage. The use of optical isolators is mandatory to ensure stable operation by blocking back reflections.

The Device is an Open-Heatsink laser diode; it may be operated in cleanroom atmosphere or dust-protected housing only.

Operating temperature and relative humidity must be controlled to avoid water condensation on the chip facets. Any contamination or contact of the chip facet must be avoided.

The performance of the Device (chip-on-carrier, chip on open-heatsink or bare die) is inherently dependent on the assembly process. When properly assembled, the Device can be expected to meet the specified performance characteristics.

ESD PROTECTION - Electrostatic discharge is the primary cause of unexpected product failure. Take extreme precautions to prevent ESD. Use wrist straps, grounded work surfaces and rigorous antistatic techniques when handling the product.



Part-number Identification

DFB0968000TC60MXXXX -> 60mW output power at 968nm peak wavelength, chip in 9mm TO-can header

DFB0968D50TC60MXXXX -> 60mW output power at 968.5nm peak wavelength, chip in 9mm TO-can header

DFB0986000TC60MXXXX -> 60mW output power at 986nm peak wavelength, chip in 9mm TO-can header

NOTE: Innolume product specifications are subject to change without notice