

***SPAD without TEC***  
***(Pigtailed 3 pin TO-46 Single Photon Avalanche Diode)***



*Contents*

**General Description** ..... 3

**Electro-Optical Characteristics** ..... 4

**Mechanical Dimension & Pin Layout** ..... 5

**Other Requirements** ..... 5

**General Description**

This InGaAs/InP APD device was specially designed and fabricated for the use of single photon avalanche detection (SPAD) with external cooling systems. It can be operated at the voltage above breakdown for short period, which is called by “Geiger-mode” or “Gated mode” operation. Ultra low noise operation is possible at the case temperature of -40°C. It can be used for quantum key distribution (QKD) receiver.

**Features**

- Low capacitance less than 0.3 pF and high speed
- Operation between 1100 nm and 1600 nm
- Coaxial type pigtail
- Low noise
- 3-pin TO-46 package
- Required External cooling system

**Applications**

- Special application such as QKD, OTDR etc, which requires single photon counting application.

**Absolute Maximum Ratings**

Parameter	Conditions	Max	Unit
Forward Current	Continuous bias	1	mA
Forward Voltage	Continuous bias	1	V
Reverse Current	Continuous bias	1	mA
Reverse Voltage	Continuous bias	$V_{BR}$	V
	RF Bias (gated mode)	$V_{BR} + 10$	V
Optical Input Power	Continuous wave	1	mW

Table 1. Absolute Maximum Ratings

**Electro-Optical Characteristics**

Inspection sheet shall be appended to products when they are delivered. Test report shall be submitted in papers and in electronic media. It shall contain the major in following items.

**Optical Characteristics (Tc=25°C)**

Parameter	Symbol	Test Condition	Min	Typ.	Max	Unit
Breakdown Voltage	$V_{BR}$	$I_D=10\mu A$	60	70	80	V
Total dark current	$I_D$	$V_R = 0.98V_{BR}$		1		nA
Capacitance	$C_{PD}$	f = 1MHz, $V_{PD} = 0.9V_B$		0.1		pF
Quantum efficiency	$\eta$	M=1, 1550nm		70		%
Optical Wavelength Range	$\lambda$	-	1100		1600	nm
Responsivity	R	$\lambda = 1550nm, M=1$	0.7	0.8		A/W
Temperature coefficient of $V_{BR}$	$\Gamma$	$\Delta V_{BR}/\Delta T$		0.11		V/°C

Table 2. Optical Characteristics

**Optical Characteristics (Tc= -40°C)**

Parameter	Symbol	Test Condition	Min	Typ.	Max	Unit
AfterPulse Probability	APP	10MHz Gate Frequency 2ns Gate Pulse 20% PDE			6	%
Dark Count Rate	DCR	10MHz Gate Frequency 2ns Gate Pulse 20% PDE			0.5	KHz
Detection Efficiency	PDE	10MHz Gate Frequency 2ns Gate Pulse		20		%

Table 3. Optical Characteristics at GM operation

**Mechanical Dimension & Pin Layout**

(Unit : mm)

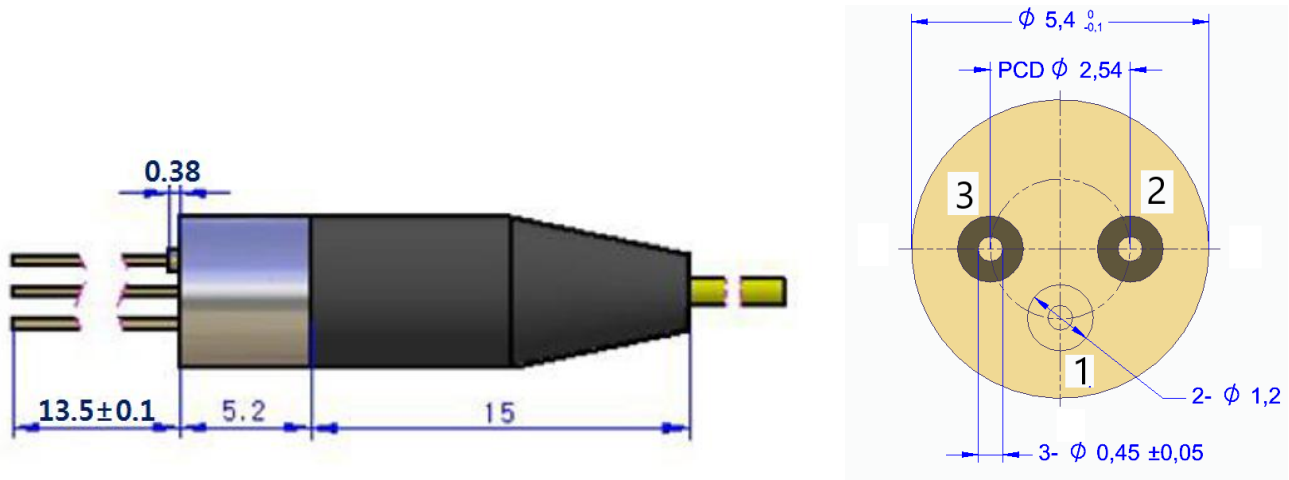

Figure 1. Mechanical Dimension

No.	Symbol	I/O	Description
1	GND	-	Ground(Case)
2	P	-	APD Anode
3	N	-	APD Cathode

Table 3. PIN Configuration

**Other Requirements**

**Precautions for use**

This device is susceptible to damage as a result of ESD(electrostatic discharge). Use of ground straps, anti static mats, and other standard ESD protective equipment is recommended when handling or testing an InGaAs PIN/APD or any other junction photodiode. Soldering temperature of the leads should not exceed 350°C for more than 3 seconds.

**ORDERING INFORMATION**

WPACPGMOSSNCNP